

PAPER • OPEN ACCESS

## The preliminary of Design and Movement of Remotely Operated Vehicle (ROV)

To cite this article: S Manullang *et al* 2020 *IOP Conf. Ser.: Earth Environ. Sci.* **557** 012006

View the [article online](#) for updates and enhancements.

# The preliminary of Design and Movement of Remotely Operated Vehicle (ROV)

S Manullang<sup>1</sup>, A Pusaka<sup>1</sup> and A Setiawan<sup>2</sup>

<sup>1</sup>Department Naval Architecture Darma Persada University, Jl. Taman Malaka Selatan, Jakarta Timur, Jakarta

<sup>2</sup>Student of Department Naval Architecture Darma Persada University, Jl. Taman Malaka Selatan, Jakarta Timur, Jakarta

Email : shanty\_manullang@ftk.unsada.ac.id, agutinus\_pusaka\_k@ftk.unsada.ac.id

**Abstract:** The purpose of this study is to design a mini Remote Operated Vehicles (ROV) which based on remote control underwater robot, and test its movements, the longitudinal and vertical movements in calm water. This research is still a preliminary research to find the best design for the ROV and its movement. The Mini ROV design is integrated into several design processes, making designs by using software, planning the selection of each component used in the mini ROV, designing mechanical construction, designing electronic construction, and the final stage is the integration of the entire design process. The results of this research decided that the best design of mini ROV is named "AF-150114. The ROV robot is made with a total dimension of 65 cm in length, 50 cm in width, and 25 cm in height. In the ROV body is made using fiberglass base material that every gap is coated with a seal so that the ROV impermeability can be maintained properly. In movement system, ROV uses two leaves of propeller to move forward and backward while using a ballast pump system to submerge and lift the ROV.

## 1. Introduction

ROV is rapidly evolving from time to time. Along with the advancement of science and the growth of technology to enable the possibilities to build from a big sized ROV to mini sized ROV. ROV is classified as a crewless submersible vehicle that is tethered to a vessel on the surface by a cable; it has a video camera, lights, thrusters that generally provide three dimensional maneuverability, depth sensors, and wide array of manipulative and acoustic devices, as well as special instrumentation to perform a variety of work tasks [1].

There are several types of underwater robots including remotely operated vehicles (ROVs), autonomous underwater vehicles (AUVs), and solar-powered autonomous underwater vehicles (SAUVs). Their application covers exploration of underwater resources, fishing industries, port security, and military operations. The tethered underwater robots are usually called remotely operated vehicles (ROVs). ROVs can take pictures underwater and carry out diverse underwater jobs [2]. The first underwater robot, Pooddle, was developed by a Frenchman Dimitri Rebikoff in 1953[3].

The underwater observation has several risk such as there are some areas that is hard to reach by human, an area of water contaminated by toxic waste, limited oxygen, hydrostatic pressure on the diver's body,



risk of animal attack and etc. Therefore, a robot that can freely move underwater is needed to help human [4].

According to Committee on Undersea Vehicles and National, there are 2 (two) kind of undersea vehicles. The first one is a vehicle that can carry human or the term that the Committee use is “manned” vehicle. The second one is a vehicle that can’t carry human or “unmanned” vehicle. Undersea vehicles broadly consist of deep submersible vehicles (DSV) which are categorized as “manned” vehicle. For “unmanned” vehicle, it consists of *Remotely Operated Vehicles* or in short ROV and Autonomous Underwater Vehicles or in short AUV. AUV is an undersea vehicle that capable of moving underwater automatically without any control by human, while ROV is an undersea vehicle that needs direct control by human through a remote control from above the water [5]. At the moment, the development for underwater robot is currently emphasized on ROV instead of AUV, the reason behind that is because ROV have the advantage to do duties that demand high precision. ROV is powered by electrical and controlled through control system, can maneuver according to human orders with thrust or electric booster [6].

Unfortunately, Indonesia has not taken advantage of this advancement. In Indonesia, there is only a few ROV that currently being developed [7,8,9] by designed ROV as water observation tools. The main problem of Indonesia water exploration right now is observation Technology, and has been developed an underwater observation technology ROV in the Sunda strait water. But It has limitation in maneuverability, which can only move up and down in a certain depth [10]. Based on these circumstances, the researcher wants to build and design ROV which can be used as a man to explore under water. Even though robots for underwater operations have been actively developed throughout the world, a commercial ROV for underwater by using a body had not been introduced especially in Indonesia. The purpose of this research is to create a design of ROV that has body, design an underwater robot that can be controlled by remote control, attempt the movement of the robot underwater on calm water as a The preliminary of Design of ROV.

## 2. Methodology

The methodology used in this research is Research and Development. While the analysis used is S.M.A.R.T which stands for Specific, Measurable, Achievable, Realistic and Time-based [11]. The design on this research includes the design of the hardware and software.

To test the body of ROV can move in water we use the Archimedes’ principle, an object that is immersed in part or in full into a fluid will experience an upward force which is equal to the weight of the fluid that it transfers [12].

$$F_a = \rho V g \quad (1)$$

Where:

$F_a$  =upward force (N)

$V$  = volume of immersed object (m<sup>3</sup>)

$\rho$  = density of liquid (kg / m<sup>3</sup>)

$g$  = acceleration due to gravity (N / kg)

The design on this ROV uses the Archimedes’ principle, for:

### 2.1 Sinking

An object that immersed into liquid will sink if the mass of the object ( $w$ ) is bigger than the buoyant force ( $F_a$ ).

$$w > F_a \quad (2)$$

Where:

$W$  = density (kg/m<sup>3</sup>)

$F_a$  = Buoyant force (N)

### 2.2. *Suspended in Depth*

An object that immersed into liquid will be suspended in depth if the mass of the object ( $w$ ) is equal to the buoyant force ( $F_a$ ) or the object is in equilibrium state.

$$w = F_a \quad (3)$$

Where:

$W$  = density ( $\text{kg/m}^3$ )

$F_a$  = Buoyant force (N)

### 2.3. *Upward Movement*

An object that immersed into liquid will float if the mass of the object ( $w$ ) is smaller than the buoyant force ( $F_a$ ).

$$w < F_a \quad (4)$$

Where:

$W$  = density ( $\text{kg/m}^3$ )

$F_a$  = Buoyant force (N)

### 2.4. *ROV Design Research*

ROV named AF-150114 aims to observe the condition of the environment underwater visually. AF-150114 can be classified as a mini class observation ROV, class 1 – pure observation and class V prototype or a vehicle in development [13]. Before the manufacturing process, the main components of the ROV need to be carefully selected and planned.

The conceptual design of AF\_150114 able to perform its motions during underwater operation. There are two horizontal thrusters installed at the body of ROV, the function of these two thrusters is to enable the ROV from moving up and down.

The components are as followed:

1. Electronic circuits. The circuit that being used for this underwater robot is Sanyou SARM-S-105D4. This item has input/output line with 32 pins, communication line serial number RS232 with RJ11 connector, and a port to program. Sanyou SARM-S-105D4 consists of regulator on the integration board that regulates the voltage with the value of 3,5 Volt which is an ADC (analog-to-digital converter) to read the voltage that comes out from H48C. All the components are integrated in one module board with the size of:
  - Long = 17,8 mm
  - Width = 20,3 mm.
2. ROV ballast pump system. Basically, there are two methods to submerge a submarine, that is by make it dive dynamically or statically. There are a lot of submarine models that use dynamic static and system. Dynamic system is a system where a submarine uses a “fin” (hydroplane) and assisted with the speed of the submarine to help the submarine to dive even deeper or to go up to the water surface. The system designed on AF-150114 use the static ballast system considering the principal dimension (of the ROV) is relatively small and it’s quite simple for the process of applying static ballast system.
3. Motor drive circuit. The circuit on AF-150114 has a DC powered motor.
4. The visual ability design for the ROV. This design phase is divided on several parts, that is:
  - a. Lighting. The purpose of the lighting in this ROV is to help the visual capabilities through the camera of the ROV, because the minute the ROV goes even deeper underwater, there will be lesser and lesser light that went through the water that will impact the visibility through the camera. This ROV has 2 LED lights with the size of 2 cm which was wrapped with a pipe connector with the size of 2,5 cm and protected with a seal to avoid the risk of water leak.
  - b. Visual camera. The camera purpose is to provide visual image while the ROV is underwater. The ROV uses a CCTV camera which is equipped with infrared light and protected with a seal to avoid the risk of water leak.

- c. ROV control system. The control system on this ROV uses switch 3 channel to take commands and regulate the ROV's maneuver, pump and the lightings of the ROV.

The ROV design is obtained through the implementation of 3D modelling design software, such as Google Sketch Up 3D and AutoCAD 2D. The final design is based on the first sketch and the utilization of every area and volume of the ROV (considering the size of this ROV is quite small).

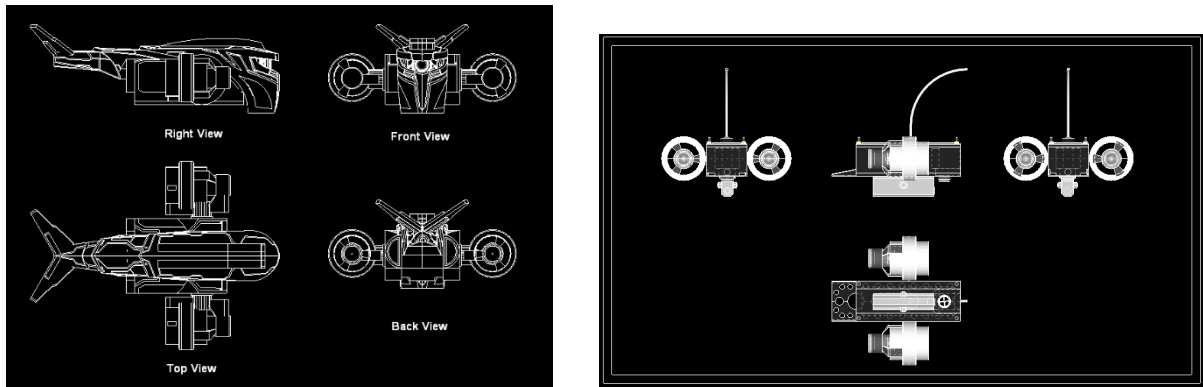
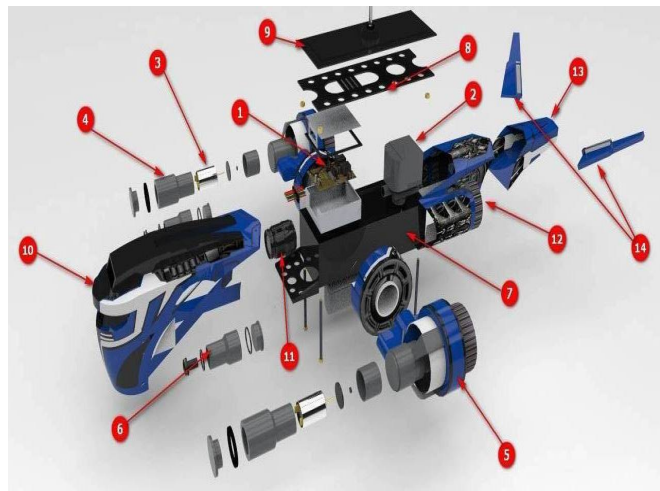

**Figure 1.** Component Design of the ROV

Above is the exterior design of ROV to contains every component which was explained on the previous part. After designing the exterior, then the 3D modeling is made with the assistance of a Google Su8 software which is the same software that were used to design the water-tightness of the ROV.

Below are the ROV parts:

1. PCB control
2. Submersible pump
3. Motor
4. Motor house
5. Body thruster
6. Lightings
7. Ballast tank
8. Tank construction
9. Tank cover
10. Front body
11. Camera
12. Air tank cover
13. Water circulation body
14. Fin stabilizer/counterweight



**Figure 2.** The exterior design of the ROV

### 3. Result and Discussion

Once the final conceptual design of the ROV- AF-150114 finished the construction process started directly. After analyzing, the ballast tank of the ROV, which will be used to dive or go back up to the water surface, needs to have a pump that can supply water with the rate of 12.50 cm/s to 25.0 cm/s, with the time to fill the tank around 10 seconds to 20 seconds. The reasoning of choosing the pump speed is by considering this class observation ROV needs to be able to maintain its stability during underwater. If the pump speed is 6.25 cm/s, it would cause the ROV to dive really fast and could affect the stability

of the ROV, in the other hand, if the pump speed is 31.25 cm/s, it would cause the ROV to have a poor maneuver capability because it would take too long to dive. Shown in table 1.

**Table 1.** Ballast Tank Analysis

Ballast Tank Volume (cm <sup>3</sup> )	Time (s)	5	10	15	20	25
		Water Debit (cm/s)	6.25	12.50	18.75	25.00
100	=	112.0	56.0	37.3	28.0	22.4
80	=	89.6	44.8	29.9	22.4	17.9
60	=	67.2	33.6	22.4	16.8	13.4
40	=	44.8	22.4	14.9	11.2	9.0
20	=	22.4	11.2	7.5	5.6	4.5

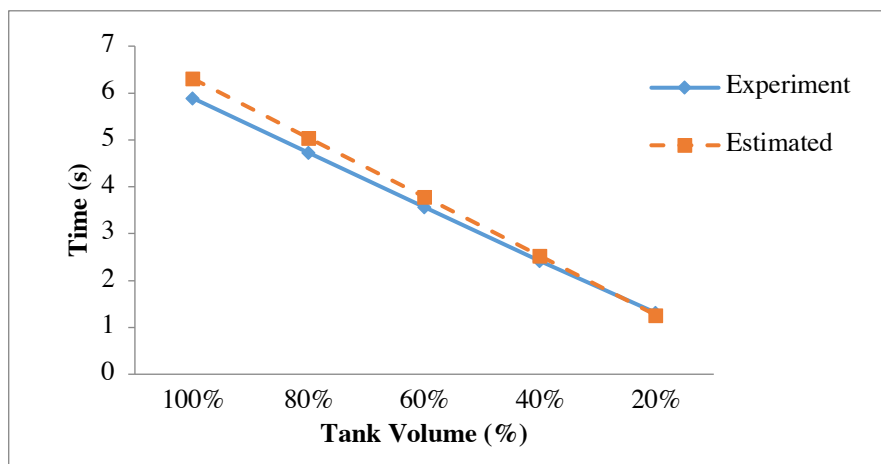

**Figure 3.** The Comparison Pump Test

**Table 2.** Analysis of Comparison of Water Filling Time

Ballast Tank (%)	Experiment (s)	Estimated (s)	Error (%)
100	5.89	6.306	0.416
80	4.73	5.045	0.315
60	3.57	3.784	0.214
40	2.42	2.523	0.103
20	1.31	1.261	0.049

As shown in Table 2 and figure 3, the results show that to full the ballast tank during the estimated is slightly faster than the experiment. Both the experiment and estimated minimum time results indicate

that the 20% Blast Tank is the minimum speed and the speed maximum is when the tank 100% full at the maximum speed.

**Table 3.** ROV motor movement capability

Speed (m/s)	Distance (m)	Time (s)	Weight of the ROV (w)	Thrust (kg.m/s <sup>2</sup> )	Thrust (N)	DC Motor Power (Watt)	Torque (Nm)
0.2	0.5	5	2.289	1.145	11.228	0.164	5.614
0.4	1	10	2.289	2.289	22.447	0.327	22.447
0.6	1.5	15	2.289	3.434	33.676	0.491	50.514
0.8	2	20	2.289	4.578	44.894	0.654	89.788
1	2.5	25	2.289	5.723	56.129	0.818	140.308

The ROV motor movement capability results show that torque is dominant at the maximum time of 25 second. DC Motor Power also dominant at the maximum time of 25 second and the distance is 2.5m. ROV speed testing was done by measuring the time when the ROV moves to achieve a certain distance. Results of the speed of each distance of the ROV is increase can be seen in Table 3.

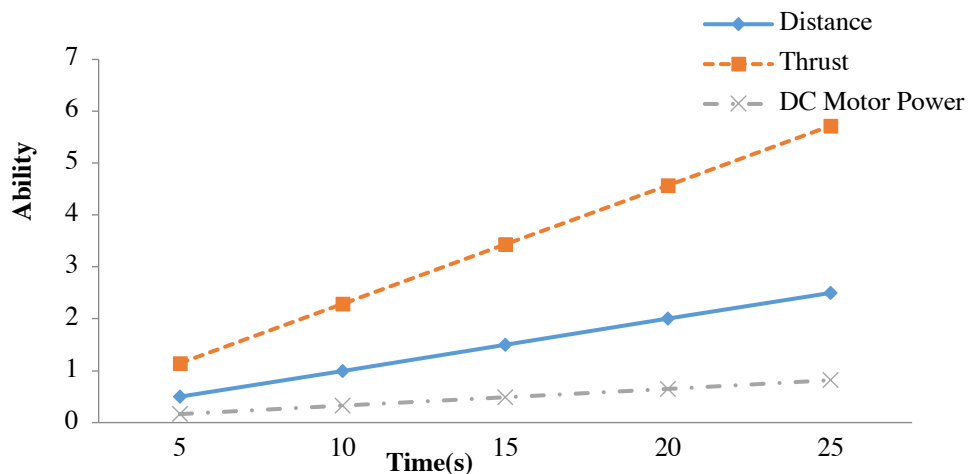

**Figure 4.** Distance, DC Motor Power and Thrust of the ROV

As show in figure 4 the ability of the ROV motor with a distance from 0.5 meters to 2.5 meters. The farther the distance traveled the more thrust and strength is needed.

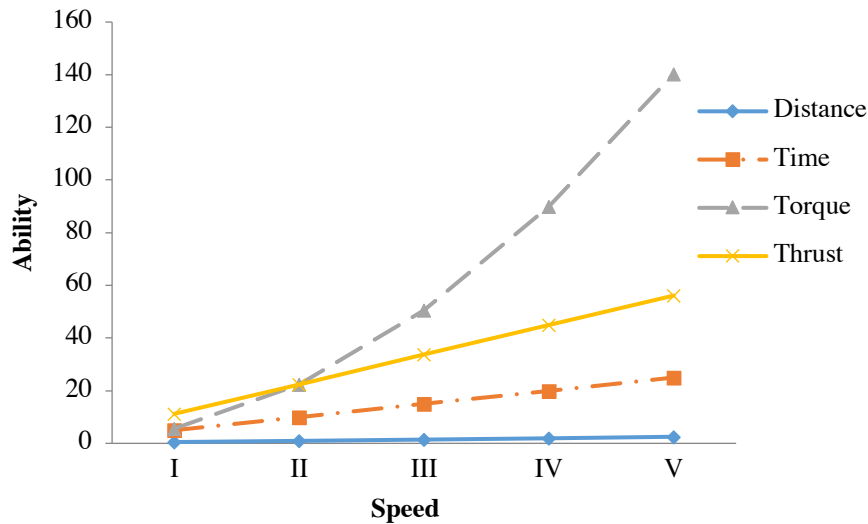

**Figure 5.** Speed, Time Thrust and torque

The torque increases in a parabolic shape as the speed increases shown in Fig 5.

### 3.1 ROV Test

The ROV AF-150114 experiment was in a pool. This experiment uses the Archimedes' principle which states "the upward buoyant force that is exerted on a body immersed in a fluid, whether fully or partially submerged, is equal to the weight of the fluid that the body displaces and acts in the upward direction at the center of mass of the displaced fluid." [14].

#### 3.1.1 Floating Test

$850.929 \text{ kg/m}^3 < 1000 \text{ kg/m}^3$  Comply with Archimedes' Principle



**Figure 6.** Floating Test

ROV position can be seen as an initial condition ROV into the water were placed in a floating position (below the waterline). It was first performed by the test of ROV weight  $850.929 \text{ kg/m}^3$  was obtained when the ROV is in float condition.

#### 3.1.2 Suspended in Depth Test

On this experiment, it was assumed the density of the ROV AF-150114 with the number of  **$850.929 \text{ kg/m}^3$** , thus it doesn't comply with  $W = F_a$  equation, therefore the ballast pump adds  **$149.071 \text{ kg/m}^3$**  with the addition of  **$0.244 \text{ kg}$**  from the ballast, then the ROV condition complies with the  $W = F_a$  equation. As shown in Figure 7 below, These conditions require ROV ballast in order to achieve a neutral position. Some testing are done by adding ballast load to get a neutral position with a total weight of ROV to  $1000 \text{ kg/m}^3$ . Mini ROV body balance greatly affects the ability to dive and movement when maneuvering [15].





**Figure 7.** Suspended in Depth Test

### 3.1.3 Upward Movement Test

On this experiment, it was assumed the density of the ROV AF-150114 with the number of **850.929 kg/m<sup>3</sup>**, thus it doesn't comply with  $W > F_a$  equation, therefore the ballast pump adds **300 kg/m<sup>3</sup>** with the addition of **0.522 kg** from the ballast, then the ROV condition complies with the  $W > F_a$  equation. Nevertheless, the additional mass from the ballast to comply with the  $W > F_a$  equation could start from **150 kg/m<sup>3</sup>** or more than that, depends on what the ROV needs.

$$\begin{aligned}\rho_{\text{TOTAL}} &= \rho_{\text{ROV}} + \rho_{\text{water ballast}} \\ &= 850.929 + 300 \\ &= 1150,929 \text{ kg/m}^3\end{aligned}$$



**Figure 8.** Sinking Test

### 3.2. Maneuver Test

**Table 4:** ROV Maneuver Test

No	Command	Result	Distance	Time (s)
1.	Forward	ok	1 m	9,2
2.	Backward	ok	1 m	13,4
3.	Left	ok	180°	10,8
4.	Right	ok	180°	10,3
5.	Rotate	ok	360°	18,7
6.	Pump in (down)	ok	1 m	7,6
7.	Pump out (up)	ok	1 m	8,4

Thruster is one of the main components as a driving force in the operation of the underwater robot. This allows the motion performance of underwater robots to move as desired as maneuvering horizontally to

move forward and move backward and maneuver vertically to move up or move down [16]. From the underwater trial tests, the ROV- AF-150114 was able to perform all maneuvering tests (table 4) like moving forward, reverse, left, right and submerge. The ROV- AF-150114 move backward is slower than move forward at the same distance of 1 meter. The problems in these maneuvering tests were large turning radius and slow reverse speed. The distance between the two thrusters quite are close to each other, resulting in a large turning radius.

#### 4. Conclusion

1. To make the robot structure watertight, it's required for the structure to be sealed with rubber, coated with wax and resin. The said procedures are able to prevent the water from going in to the robot structure and preferably, the circuit inside the robot is to be isolated.
2. The ROV can move in 3 Degree of Free, that is, 2 translation motion (ROV moves forward/backward along the  $x$  axis and ROV moves up/down along the  $z$  axis) and also 1 rotational motion (ROV rotates along the  $z$  axis) and the prime mover of the ROV uses 2 propeller blades to go forward and backward. Additionally, to make the ROV dive deeper go back to the water surface, it uses the ballast pump system
3. The stability of the ROV body affects its capabilities to dive and maneuver underwater.

#### References

- [1] Azis F. A, Aras M. S., Rashid M. Z., Othman M. N., Abdullah S. S. 2012. Problem Identification for Underwater Remotely Operated Vehicle (ROV): A Case Study. *Procedia Engineering*. 41: 554–560.
- [2] Christ, Robert D., dan Wernli SR, Robert L. 2009. Observation Class ROVs Come of Age. Sixth International Symposium on Underwater Technology. China, April 2009. Wuxi.
- [3] Remotely Operated Vehicle Committee of the Marine Technology Society, History of the ROV Committee, available at: <http://www.rov.org/history.cfm> (accessed 13 June 2020).
- [4] Hyakudome, Tadahiro. 2011. Design of Autonomous Underwater Vehicle. *International Journal of Advanced Robotic Systems*. Vol. 8 No. 1. page 131-139.
- [5] Mooney, Jr., J.B. "Brad", et al. 1996. *Undersea Vehicles and National Needs*. Washington, DC: National Academy Press.
- [6] Christ, Robert D., dan Wernli SR, Robert L. 2007. *The ROV Manual: A User Guide for Observation-Class Remotely Operated Vehicles*. India: Elsevier Ltd.
- [7] I. Rizki, 2008, "Pengembangan Prototipe Remotely Operated Vehicle (ROV): Aspek Mekanis", Skripsi S1 Ilmu dan Teknologi Kelautan, Institut Pertanian Bogor.
- [8] M. Jumarang, 2013, "Transpor Volume Massa Air Di Selat Sunda Akibat Interaksi", Prosiding Semirata FMIPA Universitas Lampung.
- [9] Z. Husin, 2014, "Studi Awal Perancangan Prototipe Remotely Operated Vehicle (ROV)", *Mikrotiga*, pp. 31–36.
- [10] R. Wiryadinata, A. S. Nurliany, I. Muttakin, T. Firmansyah, 2017, "Design of a Low Cost Remotely Operated Vehicle with 3 DoF Navigation", *Bulletin of Electrical Engineering and Informatics*, vol. 6, no. 1, pp. 13–23.
- [11] Borg, W.R. & Gall, M.D. Gall. (1989). *Educational Research: An Introduction*, Fifth Edition. New York: Longman
- [12] Dugdale, R. H. 1986. *Mekanika Fluida*. Edisi Ketiga. Erlangga, Jakarta
- [13] Germanischer Lloyd (GL), 2009, *Unmanned Submersibles (ROV, AUV) and Underwater Working Machines*, Chapter 3, Page (2–1), 2009.
- [14] Streeter, V.L. and E.B. Wylie. 1985. *Fluid Mechanics*. Eight Edition. Mc Graw Hill Book Company, USA

- [15] M. A. H. Koli, E. D. Marindani, and A. Hartoyo, “Rancang Bangun Robot Bawah Air Mini ROV (Remotely Operated Vehicles) Berbasis Mikrokontroler ATmega16,” J. Tek. Elektro Univ. Tanjungpura, vol. 2, no. 1, pp. 1–10, 2015.
- [16] Abu Sharkh S., Harris M.R., Crowder R.M., Chappel P.H. & Stoll R. L. & Sykulski, J. K., Design consideration for electric drives for the thruster of unmanned underwater vehicles, 6th European Conference on peer Electronics and Application, Seville