

# LAMPIRAN

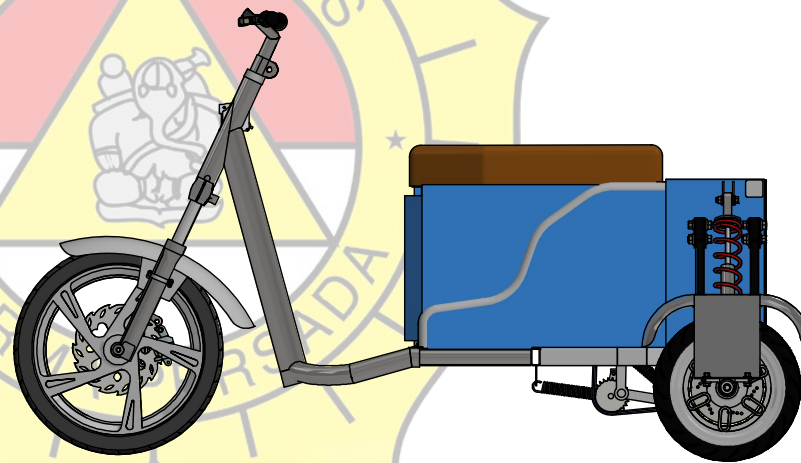

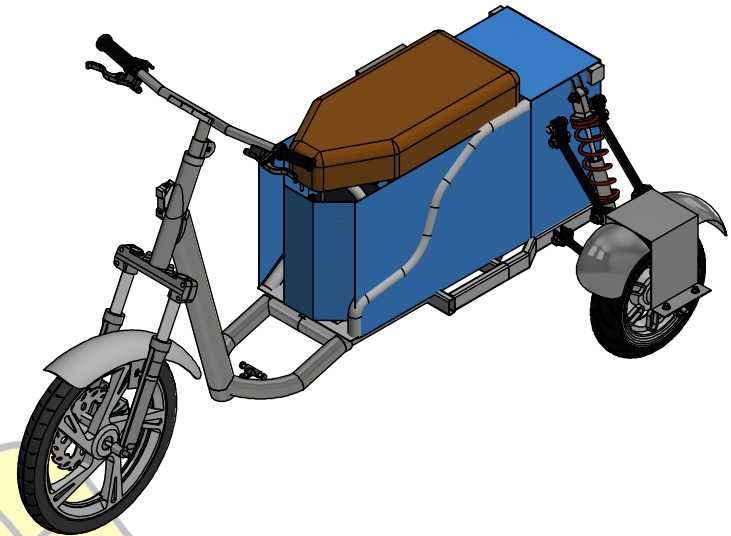

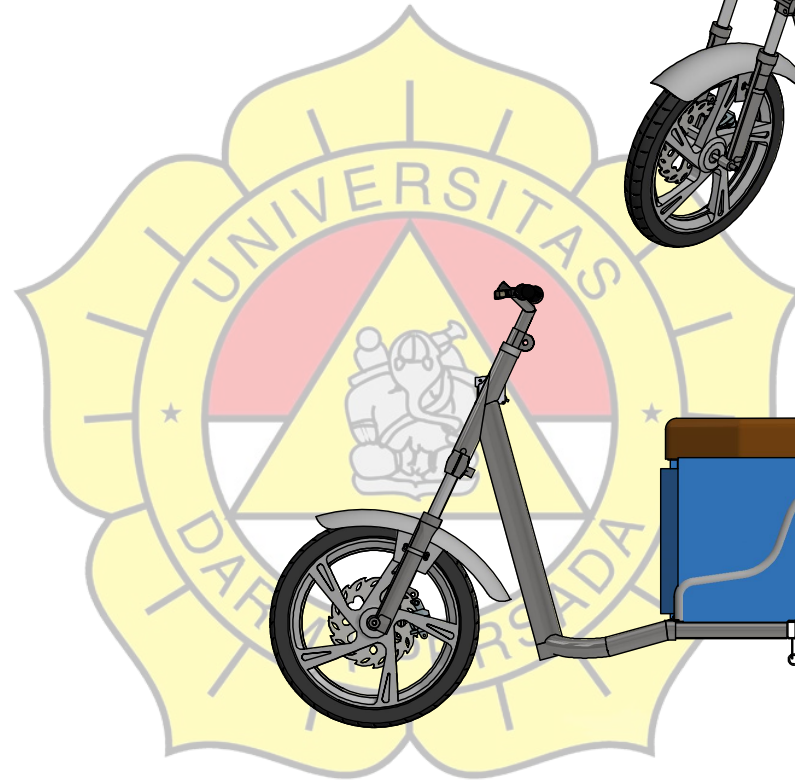
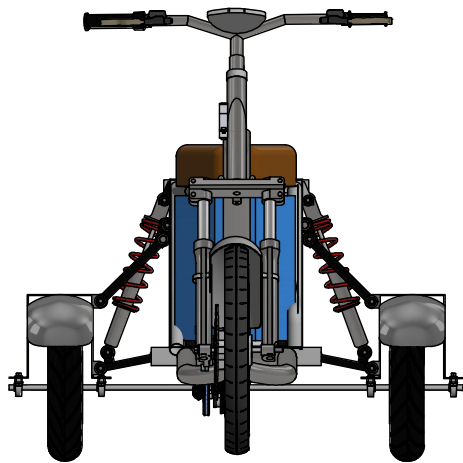

KEKASARAN DALAM $\mu\text{m}$	TOLERANSI ISO		SEPEDA LISTRIK TIGA RODA.dwg		REVISI : $\triangle$
	SKALA	0.06:1	DIGAMBAR	ACHMAD FIKI	PELANGGAN : TEKNIK MESIN
	UKURAN	dalam mm	DIPERIKSA	ROLAN SIREGAR, ST.,MT	
	TANGGAL	11-08-2021	DISETUJUI	ROLAN SIREGAR, ST.,MT	
UNIVERSITAS DARMA PERSADA		SEPEDA LISTRIK TIGA RODA			A4

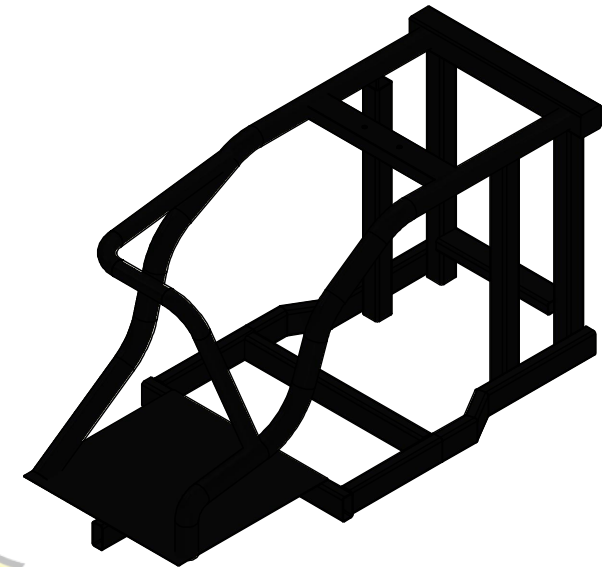
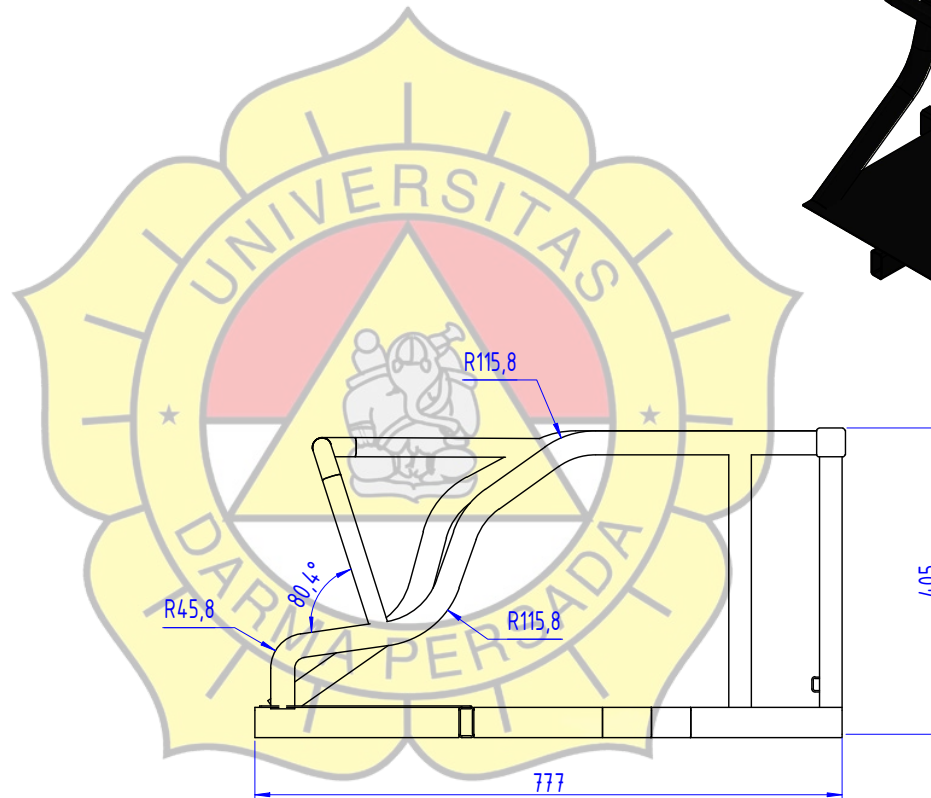
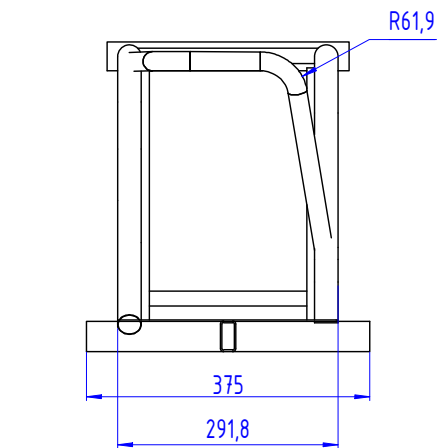
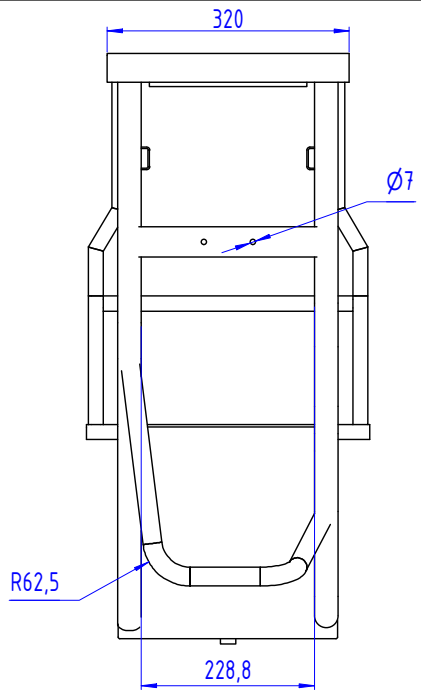

KEKASARAN DALAM $\mu\text{m}$	TOLERANSI ISO		RANGKA.dwg		REVISI : $\triangle$	
	SKALA	0.06:1	DIGAMBAR	ACHMAD FIKI	PELANGGAN :	
	UKURAN	dalam mm	DIPERIKSA	ROLAN SIREGAR, ST.,MT		TEKNIK MESIN
	TANGGAL	11-08-2021	DISETUJUI	ROLAN SIREGAR, ST.,MT		
UNIVERSITAS DARMA PERSADA		RANGKA			A4	

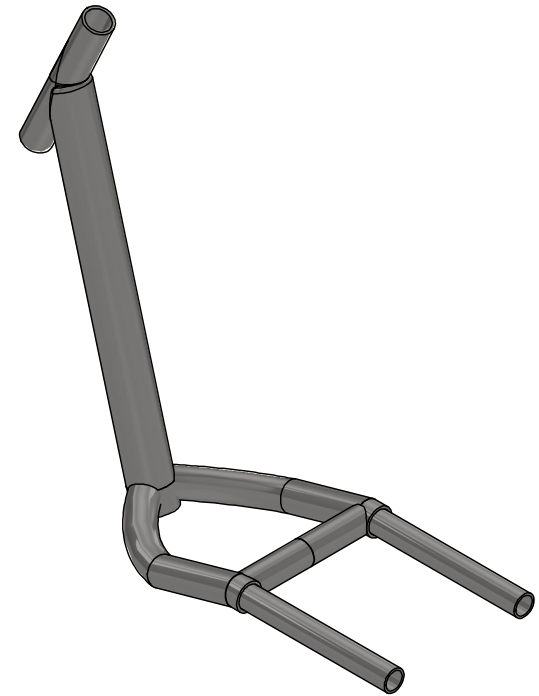
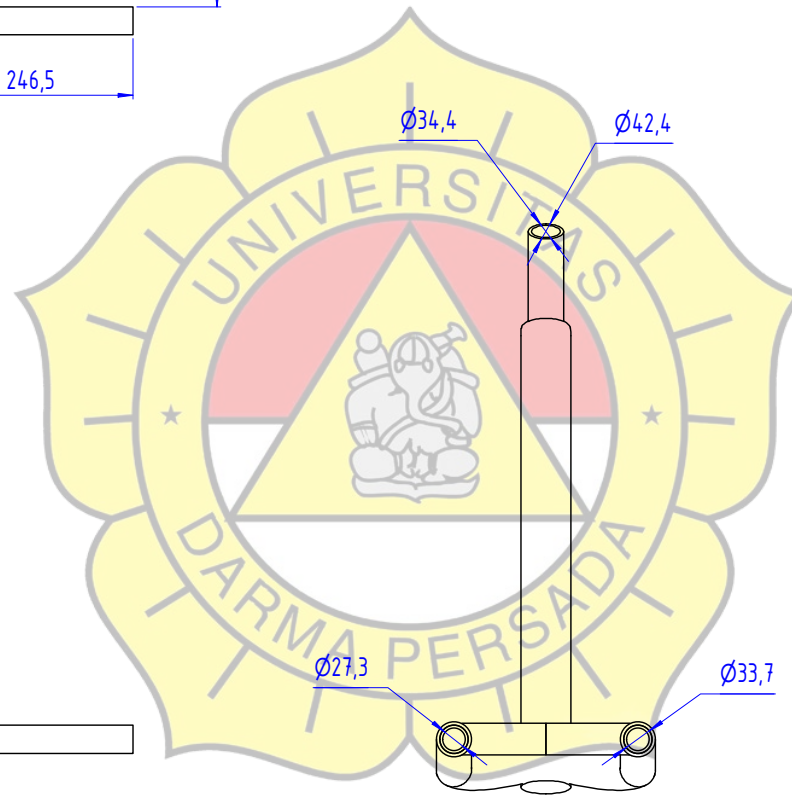
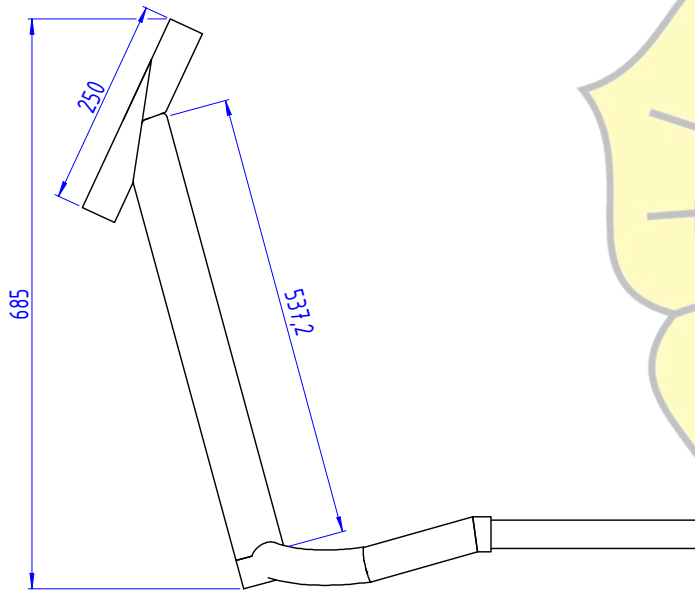
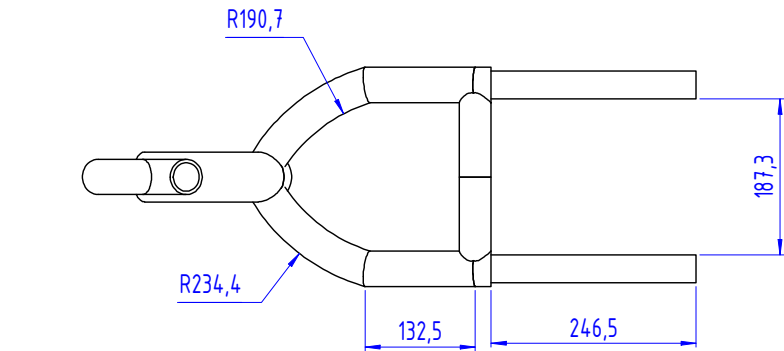

KEKASARAN DALAM $\mu\text{m}$	TOLERANSI ISO		RANGKA DEPAN.dwg		REVISI : $\triangle$	
	SKALA	0.06:1	DIGAMBAR	ACHMAD FIKI	PELANGGAN :	
	UKURAN	dalam mm	DIPERIKSA	ROLAN SIREGAR, ST.,MT		TEKNIK MESIN
	TANGGAL	11-08-2021	DISETUJUI	ROLAN SIREGAR, ST.,MT		
UNIVERSITAS DARMA PERSADA		RANGKA DEPAN			A4	

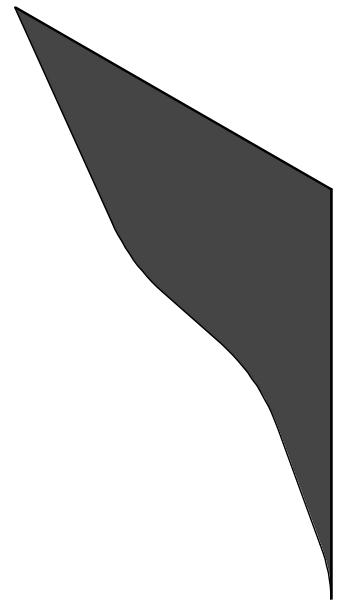
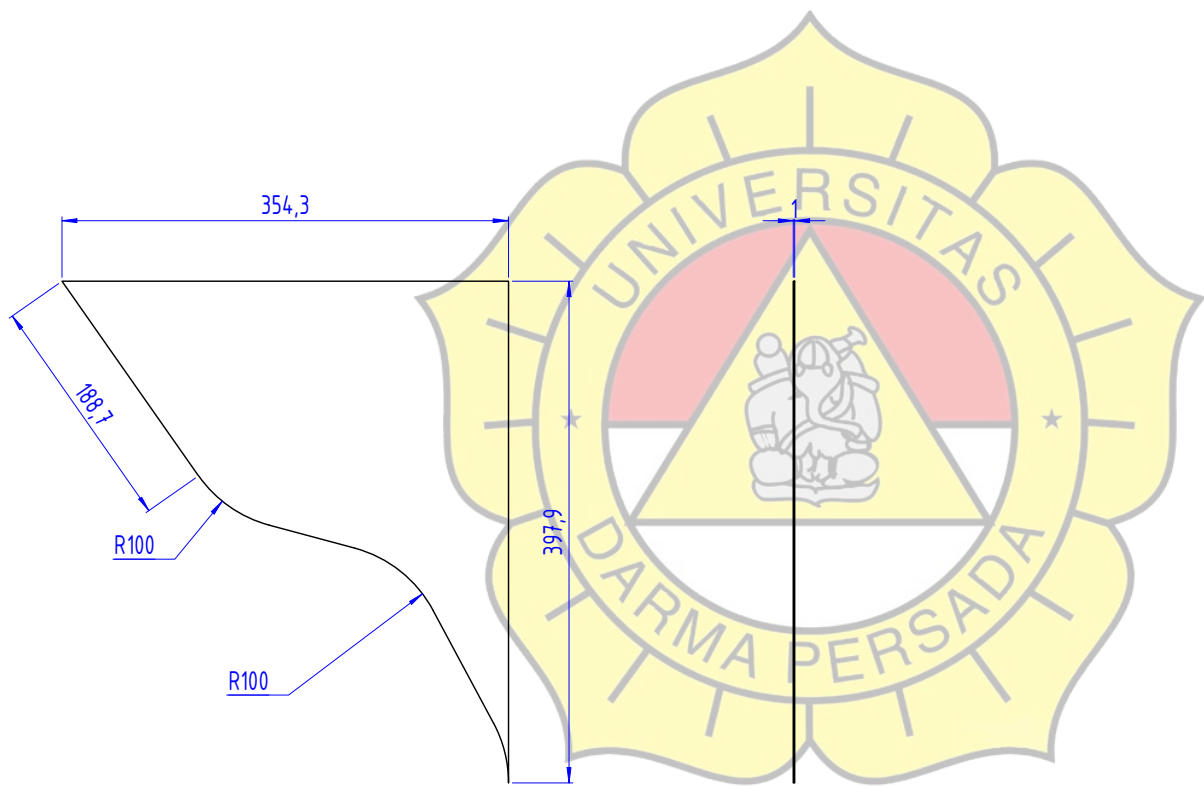

KEKASARAN DALAM $\mu\text{m}$	TOLERANSI ISO		BODY KANAN.dwg		REVISI : $\triangle$ 0
	SKALA	1:6	DIGAMBAR	ACHMAD FIKI	PELANGGAN : TEKNIK MESIN
	UKURAN	dalam mm	DIPERIKSA	ROLAN SIREGAR, ST.,MT	
	TANGGAL	11-08-2021	DISETUJUI	ROLAN SIREGAR, ST.,MT	
UNIVERSITAS DARMA PERSADA		BODY KANAN			A4

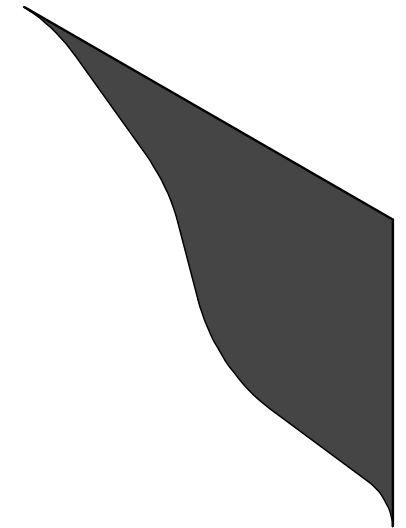
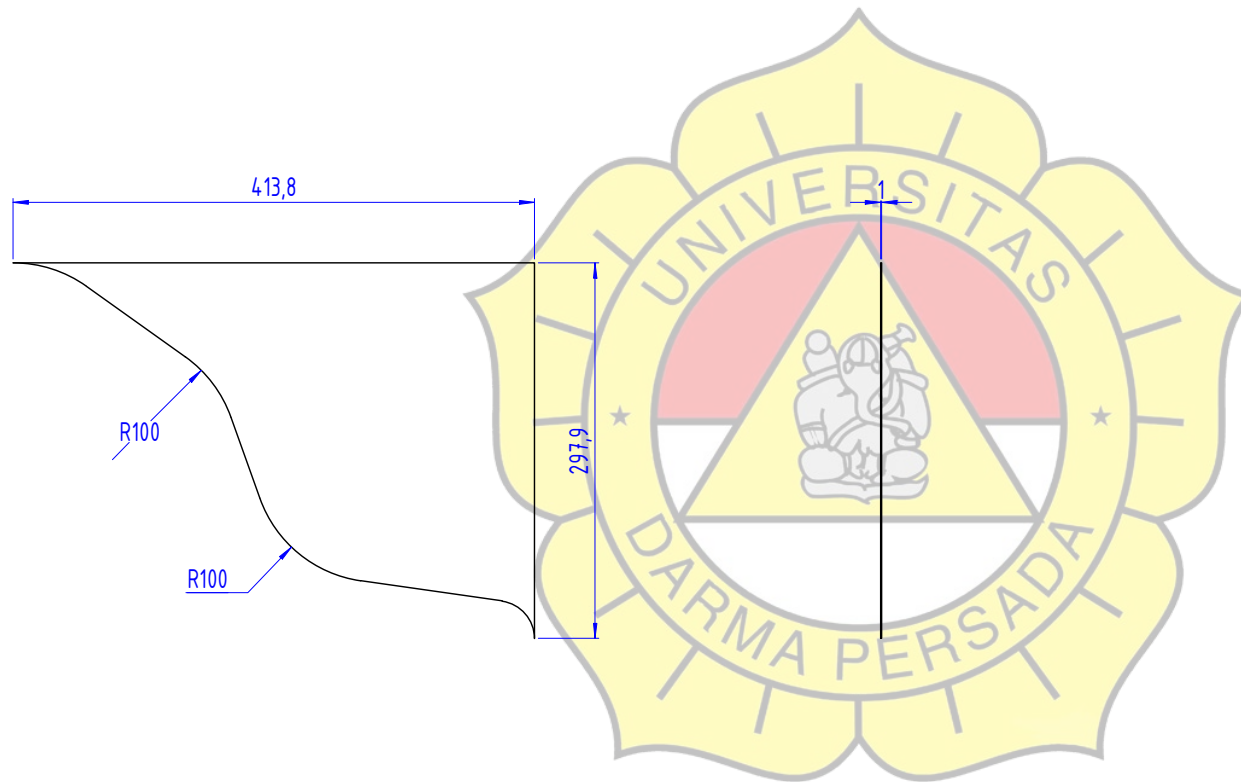

KEKASARAN DALAM $\mu\text{m}$	TOLERANSI ISO		BODY KIRI.dwg		REVISI : $\triangle 0$	
	SKALA	1:6	DIGAMBAR	ACHMAD FIKI	PELANGGAN :	
	UKURAN	dalam mm	DIPERIKSA	ROLAN SIREGAR, ST.,MT		TEKNIK MESIN
	TANGGAL	11-08-2021	DISETUJUI	ROLAN SIREGAR, ST.,MT		
UNIVERSITAS DARMA PERSADA		BODY KIRI			A4	

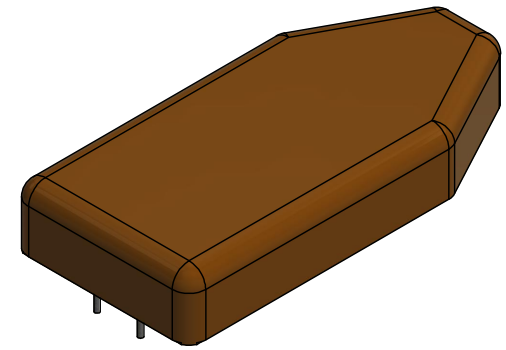
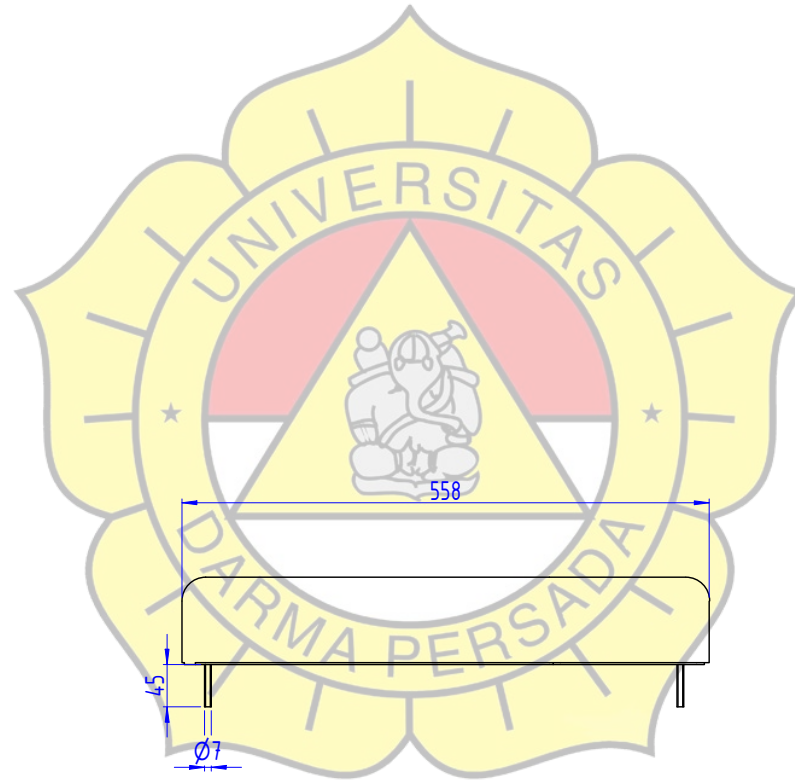
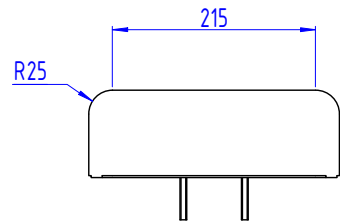
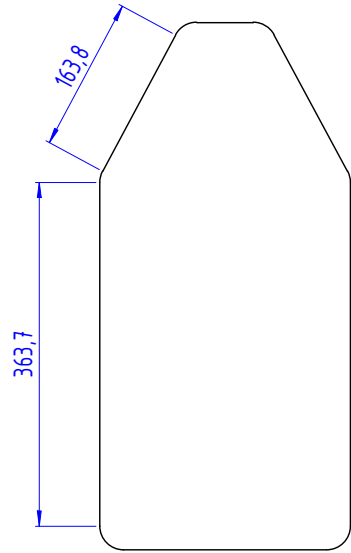

KEKASARAN DALAM $\mu\text{m}$	TOLERANSI ISO		JOK.dwg		REVISI : $\triangle$ 0
	SKALA	1:8	DIGAMBAR	ACHMAD FIKI	PELANGGAN : TEKNIK MESIN
	UKURAN	dalam mm	DIPERIKSA	ROLAN SIREGAR, ST.,MT	
	TANGGAL	11-08-2021	DISETUJUI	ROLAN SIREGAR, ST.,MT	
UNIVERSITAS DARMA PERSADA		JOK			A4



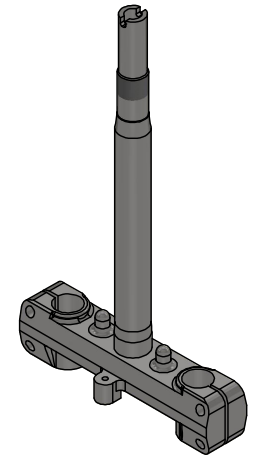
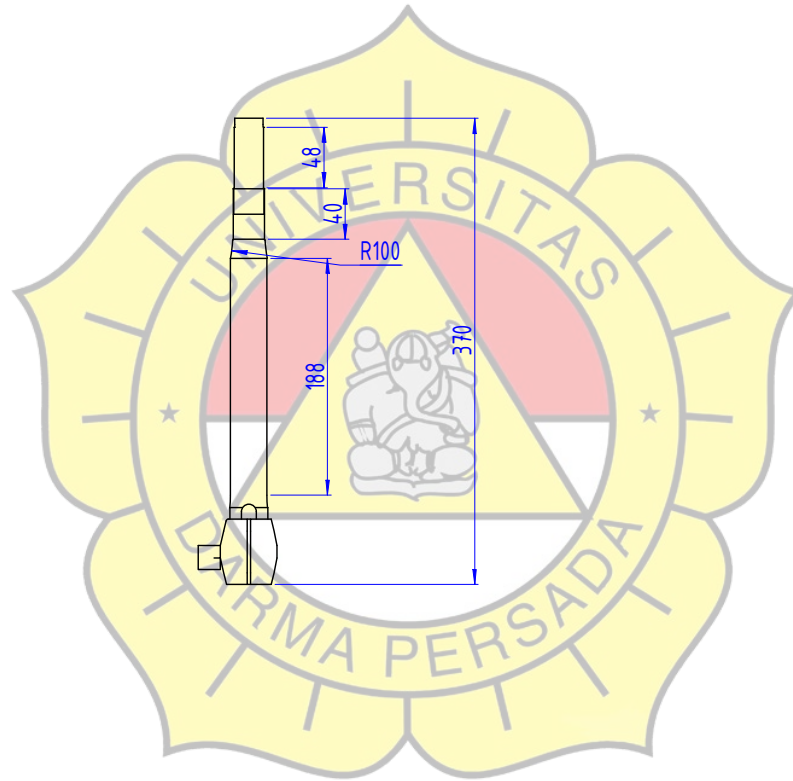
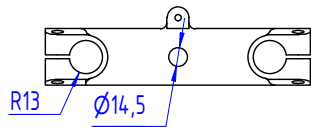
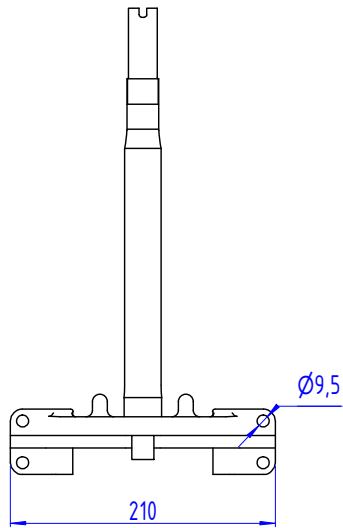
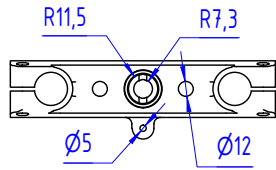

KEKASARAN DALAM $\mu\text{m}$	TOLERANSI ISO		SEGITIGA.dwg		REVISI : $\triangle 0$	
	SKALA	1:6	DIGAMBAR	ACHMAD FIKI	PELANGGAN :	
	UKURAN	dalam mm	DIPERIKSA	ROLAN SIREGAR, ST.,MT		TEKNIK MESIN
	TANGGAL	11-08-2021	DISETUJUI	ROLAN SIREGAR, ST.,MT		
UNIVERSITAS DARMA PERSADA		SEGITIGA			A4	

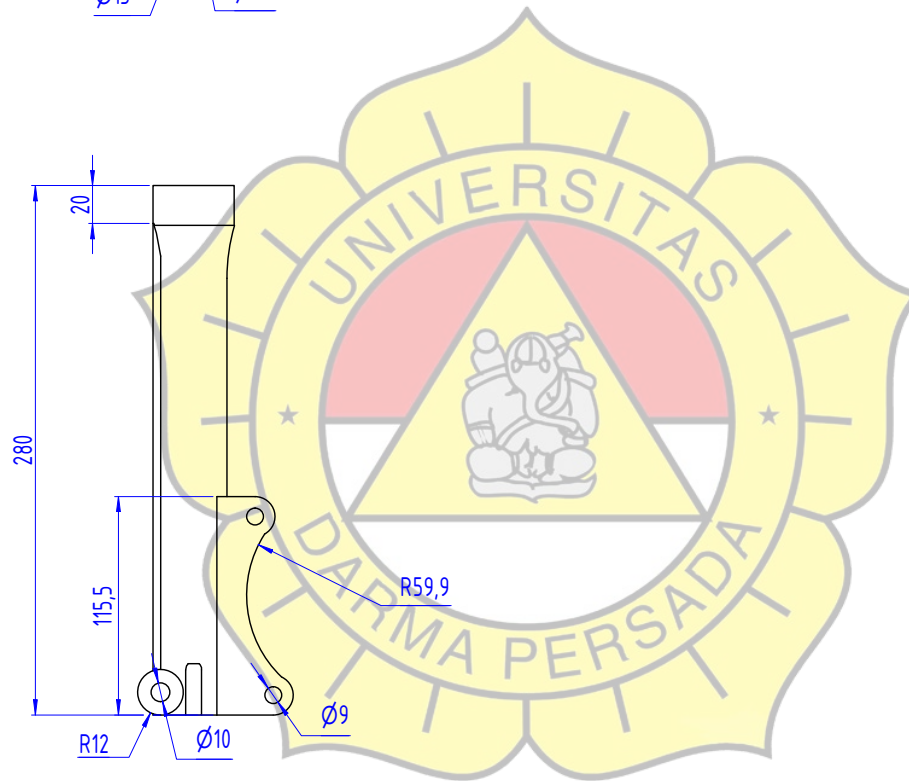
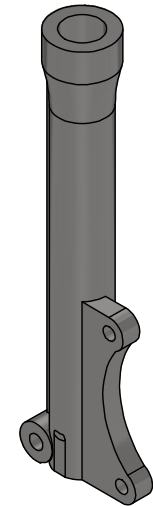
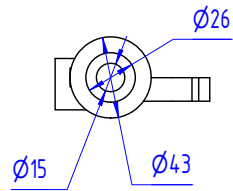

KEKASARAN DALAM $\mu\text{m}$	TOLERANSI ISO		SHOCK KANAN.dwg		REVISI : $\triangle$ 0
	SKALA	1:4	DIGAMBAR	ACHMAD FIKI	PELANGGAN : TEKNIK MESIN
	UKURAN	dalam mm	DIPERIKSA	ROLAN SIREGAR, ST.,MT	
	TANGGAL	11-08-2021	DISETUJUI	ROLAN SIREGAR, ST.,MT	
UNIVERSITAS DARMA PERSADA		SHOCK KANAN			A4

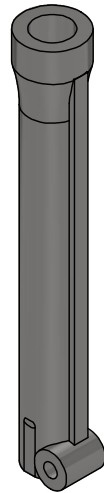
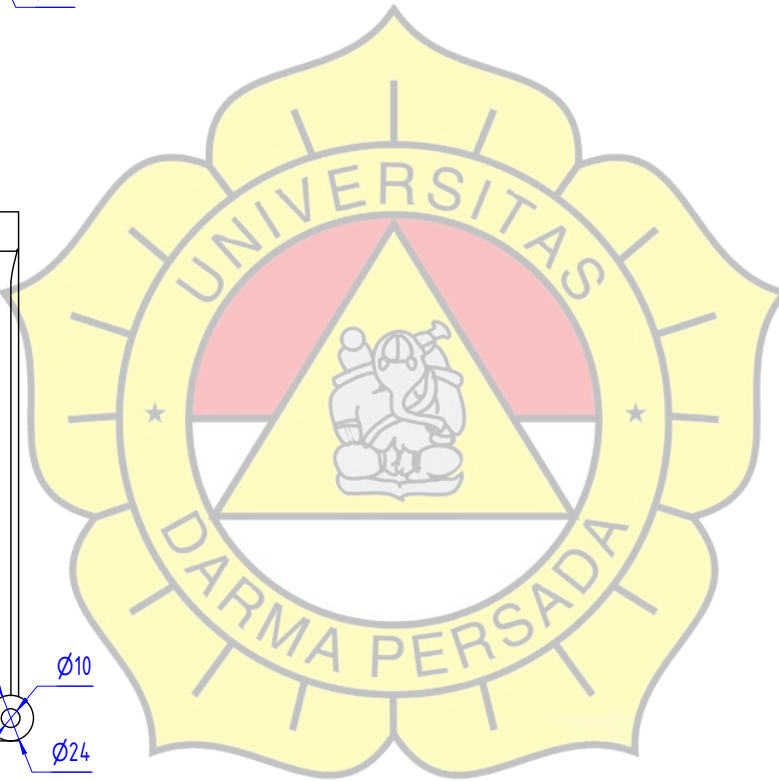
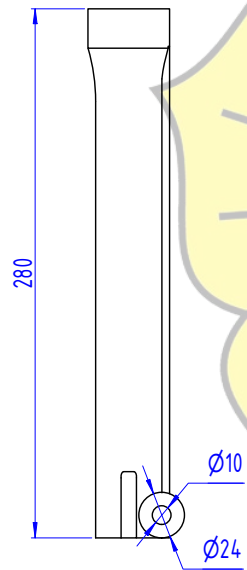
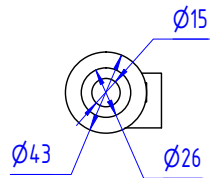

KEKASARAN DALAM $\mu\text{m}$	TOLERANSI ISO		SHOCK KIRI.dwg		REVISI : $\triangle 0$
	SKALA	1:4	DIGAMBAR	ACHMAD FIKI	PELANGGAN : TEKNIK MESIN
	UKURAN	dalam mm	DIPERIKSA	ROLAN SIREGAR, ST.,MT	
	TANGGAL	11-08-2021	DISETUJUI	ROLAN SIREGAR, ST.,MT	
UNIVERSITAS DARMA PERSADA		SHOCK KIRI			A4

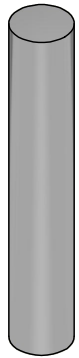
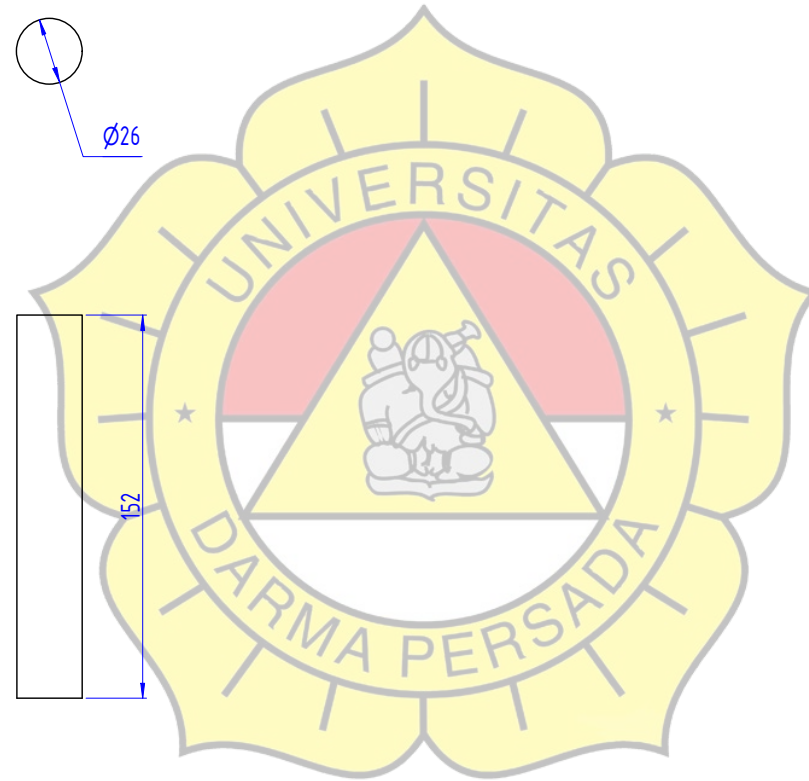

KEKASARAN DALAM $\mu\text{m}$	TOLERANSI ISO		AS SHOCK.dwg		REVISI : $\triangle 0$
	SKALA	1:3	DIGAMBAR	ACHMAD FIKI	PELANGGAN : TEKNIK MESIN
	UKURAN	dalam mm	DIPERIKSA	ROLAN SIREGAR, ST.,MT	
	TANGGAL	11-08-2021	DISETUJUI	ROLAN SIREGAR, ST.,MT	
UNIVERSITAS DARMA PERSADA		AS SHOCK			A4