



LAMPIRAN

1. Sertifikat kalibrasi *Roughness Surface Meter*



PT. Mitutoyo Indonesia



KAN
Komite Akreditasi Nasional
Laboratorium Kalibrasi
LK-103-IND

Certificate Number : IA-2664960

Date of Calibration : 11-Aug-2020

Date of Issue : 11-Aug-2020

Recommend Next Calibration In : August-2021

CERTIFICATE OF CALIBRATION

Page 1 of 2

Customer Name	: PT. BUMI CAHAYA UNGGUL		
Attention	: Mr. Yanuar	Dept.	: QC Dept
Customer Address	: JL. RAWA KEPITING NO.3 KIP, RAWA TERATE CAKUNG,		
	: JAKARTA TIMUR, DKI JAKARTA RAYA 00000		
Equipment Address	: JL. RAWA KEPITING NO.3 PULO GADUNG INDUSTRIAL ESTATE		
	: JAKARTA TIMUR 13920		
	: Calibrated at PT Mitutoyo Indonesia Jl. Sriwijaya No.26 Desa Cibatu Kec. Cikarang Selatan Kab. Bekasi 17530		
Equipment Name	: Surface Roughness Tester	Manufacturer	: Mitutoyo
Equipment Model	: SJ-210	Code Number	: 178-561-01E
Serial Number	: 601761906		
Range	: 0.01 μm ~ 360 μm		
Resolution	: 0.010 μm		
Standard Used	: JIS B 0651 (2001) Surface texture - Instruments for the assessment of surface texture - Profile method		
Calibration Procedure	: MAP-12 (Revision 3, 15 August 2014)		
Remarks	: Annual Calibration		
	: Pre-Adjustment Data refer to Annex A - Page 1 of 1		

This certifies that the equipment model has been calibrated in accordance with the required Japanese Industrial Standards (JIS) or Manufacturer's Specification or other applicable standards .

The Ambient Temperature at the time of calibration is 20.8 ° C and the Relative Humidity is 58.0 %rh

Calibration Equipment Used

Code No.	Description	Manufacturer	Serial No.	Report No.	Due date
178-604	Roughness Specimen	Mitutoyo	900150	16003	20-Feb-2023
50-0569	Straight plate	Mitutoyo	DM005448	LL001978	16-Apr-2021
SH-101	Thermo-Hygro Meter	ISO LAB	TH - 0017 - MI	S-18-0494	18-Jan-2021
RAYMT4U	Infrared Thermometer	RAYTEK	102949	C253396	28-Feb-2022
-	-	-	-	-	-
-	-	-	-	-	-
-	-	-	-	-	-
-	-	-	-	-	-

The calibration reference used have been calibrated by National Metrology Centre (Singapore) or accredited laboratory.
The results of calibration are referred to a temperature of 20° C.

Jalan Sriwijaya No.26 Desa cibatu, Kec. Cikarang Selatan Kab. Bekasi 17530 MI-WS-0.10.1-FMM-SV-c-001
Tel: +62 (21) 2962 8600 (Hunting) Fax: +62 (21) 2962 8604 E-mail: ptmi@mitutoyo.co.id

PT. Mitutoyo Indonesia

Certificate Number : IA-2664960

CERTIFICATE OF CALIBRATION

Page 2 of 2

1. Straightness of the drive unit	Specification = 0,5 μm / 17,5 mm
Measured value is 0.13 μm	Expanded uncertainty of measurements is 0.06 μm with coverage factor, k = 2.25
2. Radius of Stylus	Specification = 0,343 \pm 0.1 μm
Measured value is 0.38 μm	Expanded uncertainty of measurements is 0.20 μm with coverage factor, k = 2.04
3. Repeatability of Ra Measurement	Specification = 2.89 \pm 0.2 μm
Measured value is 2.89 μm	Expanded uncertainty of measurements is 0.20 μm with coverage factor, k = 2.04

All the expanded uncertainties of measurements for the measured values are estimated at a level of confidence of approximately 95 %.

This certificate does not imply that PTMI warrants the equipment performance after calibration and the certificate may not be reproduced except in full, without written approval by the Head of Laboratory.

The user should determine the suitability of the measuring instrument for its intended use.

Calibrated by : 
Enecep Hidayat
Calibration Officer

Approved by : 
Haris Saleh
Head of Laboratory

Pre-Adjustment Data

Items of Inspection	Permissible error	Error (μm)	Pass/Fail
Straightness of the drive unit	0,5 μm / 17,5 mm	0.1	Pass
Radius of Stylus	0.343 \pm 0.1 μm	0.35	Pass
Repeatability of Ra measurement	2.89 \pm 0.2 μm	2.98	Pass

Please refer to the following for Adjustment made to Machine

ITEM	Adjustment Y / N or NA
Straightness of the drive unit	NA
Radius of Stylus	NA
Repeatability of Ra measurement	Y

Calibrated by : 
Encep Hidayat
Calibration Officer

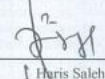
Approved by : 
Heris Saleh
Head of Laboratory

2. Sertifikat kalibrasi CMM (Coordinate Measuring Machine)



PT. Mitutoyo Indonesia



KAN
Komite Akreditasi Nasional
Laboratorium Kalibrasi
LK - 183 - IDN

Certificate Number : IA-2654201

Date of Calibration : 1-Jul-2020

Date of Issue : 6-Jul-2020

CERTIFICATE OF CALIBRATION

Page 1 of 3

Customer Name : PT BUMI CAHAYA UNGGUL

Attention : Mr. Yanuar Dept. QC Dept Tel. 0811 155 8270

Customer Address : JL. RAYA KEPITING NO. 3 KIP
RAWA TERATE, CAKUNG, JAKARTA TIMUR, DKI JAKARTA RAYA

Equipment Address : JL. RAWA KEPITING NO. 3
PULO GADUNG INDUSTRIAL ESTATE, JAKARTA TIMUR, 13920

Equipment Room : Measuring Room

Equipment Name : Coordinate Measuring Machine **Manufacturer :** MITUTOYO

Equipment Model : QM Measure 353 **Code Number :** 198-313

Serial Number : 0028007C

Range : X: 300 mm Y: 500 mm Z: 300 mm

Resolution : 0.1 μ m

Standard Used : CMM Inspection Standard ISO 10360-2; 2009 10360-5 ; 2010 as a guide

Calibration Procedure : MAP-13e (Revision 1, 28 May 2013)

Remarks : Annual Calibration
Pre-Adjustment Data refer to Annex A - Page 1 of 1

This certifies that the equipment model has been calibrated in accordance with the required International Organization for Standardization (ISO).

The Ambient Temperature at the time of calibration is 25.0 °C and the Relative Humidity is 40.0 %rh

The coefficient of thermal expansion of the checkmaster is 10.8 x 10⁻⁶ / °C

Calibration Reference Used And Traceability

Code No.	Description	Manufacturer	Serial No.	Report No.	Due Date
515-742	Check Master	Mitutoyo	210128	48370	25-Feb-2023
99CMM001	Master Ball	Mitutoyo	20-98-217	LL003009	29-Sep-2022
EM913R	Thermo-Hygrometer	Oregon Scientific	TH0009	S-18-0495	18-Jan-2021
515-741	Check Master	Mitutoyo	310101	48365	24-Feb-2023
1523	Platinum Resistance Thermometer	Fluke - Hart Scientific	2017240	03/09/200-500/137	27-Oct-2021
1523	Indicator	Fluke - Hart Scientific	2017240	03/09/200-500/137	27-Oct-2021

The calibration reference used have been calibrated by National Metrology Centre (Singapore) or accredited laboratory.

The results of calibration are referred to a temperature of 20° C.

Jalan Sriwijaya No.26 Desa cibatu, Kec. Cikarang Selatan Kab. Bekasi 17530 MI-WS-5.10.1-CMM-e-001
Tel: +62 (21) 2962 8600 (Hunting) Fax: +62 (21) 2962 8604 E-mail: ptmi@mitutoyo.co.id

CERTIFICATE OF CALIBRATION

1. Length measurement error and its repeatability range

		$E_{\text{MPE}} = \pm (3 + 4L/1000) \mu\text{m}$			$R_{0.95L} = \pm 3 \mu\text{m}$	
E₀₋₁, parallel to x-axis	Length (mm)	30	90	150	210	270
	Mean Error (μm)	-0.7	-1.0	-1.0	-1.3	-1.6
	R₀₋₁ Repeatability (μm)	0.3	0.3	0.2	0.1	0.2
Expanded uncertainty of E ₀₋₁ measurement is		2.1 μm with coverage factor, k = 2.00				
E₀₋₂, parallel to y-axis	Length (mm)	30	150	250	370	470
	Mean Error (μm)	-0.6	-0.9	-0.9	-1.2	-1.4
	R₀₋₂ Repeatability (μm)	0.2	0.1	0.3	0.2	0.1
Expanded uncertainty of E ₀₋₂ measurement is		3.6 μm with coverage factor, k = 2.00				
E₀₋₃, parallel to z-axis	Length (mm)	30	90	150	210	270
	Mean Error (μm)	-0.6	-0.8	-1.0	-1.3	-1.5
	R₀₋₃ Repeatability (μm)	0.2	0.1	0.2	0.1	0.1
Expanded uncertainty of E ₀₋₃ measurement is		2.1 μm with coverage factor, k = 2.00				
E₀₋₄, XYZ plane diagonal	Length (mm)	30	90	210	310	410
	Mean Error (μm)	-0.4	-0.9	-0.9	-1.4	-1.7
	R₀₋₄ Repeatability (μm)	0.8	0.1	0.1	0.2	0.1
Expanded uncertainty of E ₀₋₄ measurement is		3.2 μm with coverage factor, k = 2.00				
E₀₋₅, XYZ plane diagonal	Length (mm)	30	90	210	310	410
	Mean Error (μm)	-0.6	-0.8	-1.0	-1.4	-1.6
	R₀₋₅ Repeatability (μm)	0.2	0.2	0.2	0.2	0.1
Expanded uncertainty of E ₀₋₅ measurement is		3.2 μm with coverage factor, k = 2.00				
E₀₋₆, XYZ plane diagonal	Length (mm)	30	90	210	310	410
	Mean Error (μm)	-0.7	-0.9	-1.0	-1.6	-1.7
	R₀₋₆ Repeatability (μm)	0.2	0.1	0.1	0.2	0.2
Expanded uncertainty of E ₀₋₆ measurement is		3.2 μm with coverage factor, k = 2.00				
E₀₋₇, XYZ plane diagonal	Length (mm)	30	90	210	310	410
	Mean Error (μm)	-0.8	-0.9	-1.0	-1.7	-1.8
	R₀₋₇ Repeatability (μm)	0.1	0.0	0.1	0.1	0.1
Expanded uncertainty of E ₀₋₇ measurement is		3.2 μm with coverage factor, k = 2.00				

L : Measured Length in mm

3. Gambar Mesin 3D Printing

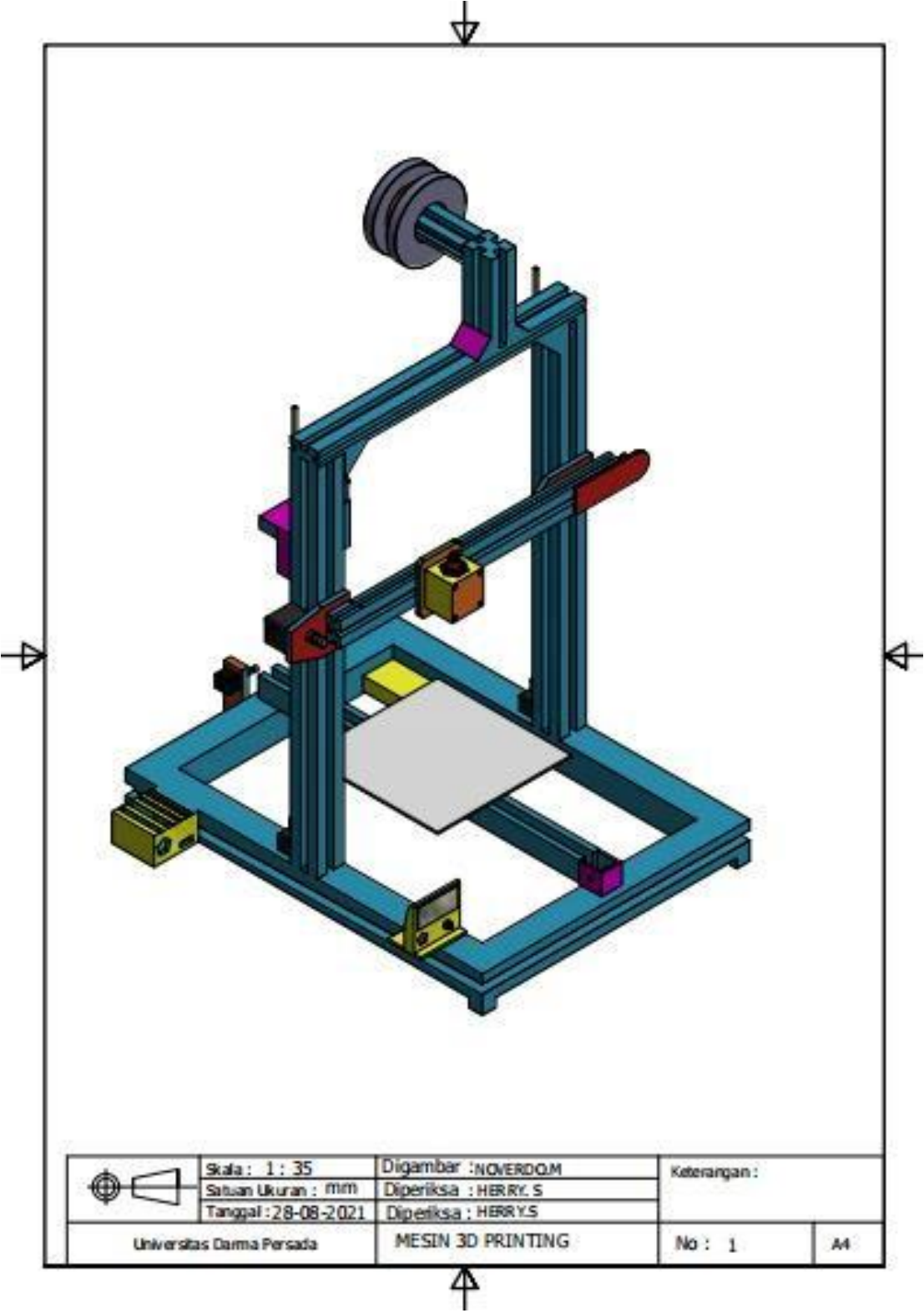

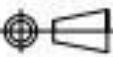
	Skala : 1 : 35	Digambar : NOVERDOM	Keterangan :	
	Satuan Ukuran : mm	Diperiksa : HERRY.S		
	Tanggal : 28-08-2021	Diperiksa : HERRY.S		
Universitas Darma Persada	MESIN 3D PRINTING	No : 1	A4	