

PAPER • OPEN ACCESS

## Design of leak testing machines for automatic generic drug packaging pressure capacity of 0.4 atm

To cite this article: Didik Sugiyanto *et al* 2020 *J. Phys.: Conf. Ser.* **1444** 012041

View the [article online](#) for updates and enhancements.

You may also like

- [The Role of Packaging Technology in The Food Product](#)  
A. M. Mahmed, B. H. Mohammed and L. K. Hassen
- [The Legality of food packaging to the production of small and medium enterprises \(SME\)](#)  
Emy Handayani, Iga Gangga Santi Dewi, Wahyu Purnomo et al.
- [An affective design for jenang packaging in Indonesia](#)  
A N Habyba, Delfitriani and T Djatna



The Electrochemical Society  
Advancing solid state & electrochemical science & technology

242nd ECS Meeting

Oct 9 – 13, 2022 • Atlanta, GA, US

Abstract submission deadline: **April 8, 2022**

Connect. Engage. Champion. Empower. Accelerate.

**MOVE SCIENCE FORWARD**



Submit your abstract



# Design of leak testing machines for automatic generic drug packaging pressure capacity of 0.4 atm

**Didik Sugiyanto, Husen Asbanu and Ahmad Ajmil Mustofa**

Department of Mechanical Engineering, Darma Persada University  
Pondok Kelapa, South Jakarta, Indonesia

Corresponding author email : didik\_sugiyanto@ft.unsada.ac.id;  
husen\_asbanu@ft.unsada.ac.id; ahmad\_ajmilmustofa@ft.unsada.ac.id.

**Abstract.** The quality of packaging becomes a matter of concern that is packaging because it can produce the quality of the product being packaged, it is very necessary to have supplies for packaging on the packaging automatically. The purpose of this study is to help overcome the problem of packaging during the initial setup process before entering the packaging machine. The research method used is the design and discuss the function of machinery. Manufacture of packaging testing machines with 900 mm x 600 mm x 906 mm. Estimated to be 99,992,268 N/m<sup>2</sup>. The Control Program can be used using the Arduino UNO program. The process of vacuuming the waiting time for 2 minutes, the marking process is complete, then the pressure indicator returns to zero and the alarm sounds.

## 1. Introduction

The rapid development of science and technology in the industrial world makes everyone pay more attention to the quality of a product including the packaging used on that product. Packaging is an important aspect compared to a product. Good packaging is not only related to visual products but also to the quality of the products they have. Packaging has several purposes, namely as a protector of packaged products, tools to facilitate the distribution and sales process, as a media for information and promotion of products, as well as anti-theft devices.

Packaging is an important part that needs attention due to the quality of the product. One of the important things that must be removed from the packaging process is the existence of the packaging provided, therefore a special machine is needed to find out the backup on the package. in the process of making food and medicine specifically in making packaging there needs to be a better tool design about the purchase costs of the packaging process for food products and medicines related to repairing leaks in packaged products.

In its development various ways have been done to request a return on the packaging so that the product must be safe for consumption. Currently in the process of checking leakage, packaging machines used in leak protection are still manual without using a special machine that works by using automatic testing takes longer to get a package that is really safe and does not leak.

The purpose of this study is to validate a machine that can be used automatically for packaging medicine in the initial setting. The manufacturing industry is highly affected by trends of mass customization and increasing dynamics of product life-cycles which result in a large set of part variants. Thus, the required effort for logistics planning and, in particular, for packaging planning is increasing. This paper proposes an approach to automate the assignment of packaging for an



individual part based on its characteristics using machine learning. We use the historical data of product parts and their packaging specifications to train our two-step machine learning model. Consequently, the model is able to propose a packaging with an accuracy of 84% in comparison with real-world data [1].

Helium leak testing could be implemented as an integrity method for various types of flexible and rigid containers. Various examples showed the advantages of helium leak testing in the selection of a container system and the optimization of the closing parameters thus ensuring the drug product quality and stability. The studies performed also demonstrate the versatility of a helium leak tester with a flexible test chamber for flexible and rigid containers for oral drug products [2].

Leaks in medical device, pharmaceutical, and food packages may result in the ingress of unwanted gases (most commonly oxygen), harmful microbiological, or particulate contaminants. Package leaks may appear as imperfections in the package components themselves or at the seal juncture between mated components. The ability to detect leaks is necessary to ensure consistency and integrity of packages [3].

Polygraph varnishes are widely used in the production of food packaging's. Currently, free radical cured varnishes are most widespread. The presented results prove that: the photo initiator concentration required to obtain cured varnish layer of good physical properties depends on the type of packaging material as varnish support. The type of packaging material is strongly responsible for the migration degree of the photo initiator to packed food products. There is no relation between the roughness of packaging material surface and the surface roughness of varnish layer formed on it [4].

Product labeling is among the most important tools to assist pharmacists. A label should be designed in such a way that product selection and dispensing tasks are performed accurately in order to help ensure patient safety. The goal of this project was to develop a scientific approach to label design through human factors engineering and usability studies and based on feedback from the FDA. The approach included collaboration with independent experts from a medication safety company as well as a human factor engineering firm. Prior to the usability test phase of the project, an initial assessment of the current and proposed package label designs identified strengths and potential areas of concern that might increase the risk of a dispensing error. The independent experts then designed and conducted a preliminary (i.e., formative) usability study of four package label designs developed based on the initial label assessment. The resulting quantitative and qualitative data informed the selection and refinement of the final design that was subsequently validated. The validation suggests that the final label design could be safe and effective for use in an outpatient pharmacy setting. [5]

The term packaging is frequently used in different applications and scenarios, and consequently there are various definitions and perspectives. We briefly summarize the definitions as follows [6]:

- Packaging goods: the parts which are packed
- Packaging: the container which holds the packaging goods
- Package: the packaging including the packaging goods
- Packaging aids: protective layers inside the packaging

Leaks should be detected before the product reaches the consumer. Designing a device that can detect leaks in bottles can be a solution to help detect leaking packages. The tool will be integrated in the production process, so that if there is a leak on the packaging it will not enter the next production process. So it needs an accurate tool to detect leaks using the MPX 5100 pressure sensor so that it becomes more accurate, faster, and reliable and integrated with the microcontroller and the database [7].

## 2. Experimental

### 2.1. Material

The materials used in making generic drug packaging leak testing machines are:

**Table 1.** Components and materials used in the design

No	Material
1.	Vacuum pump
2.	Pressure indicator
3.	Arduino Uno
4.	Relay
5.	Start, stop, power button
6.	Cable
7.	Adapter
8.	Cubing 10
9.	Hose 10
10.	Water faucet
11.	Iron pipe $\varnothing$ 320 mm
12.	Round iron $\varnothing$ 350 mm
13.	Seal $\varnothing$ 340 mm
14.	Sheet iron plate
15.	Hollo 4 bars for frame size $40 \times 40 \times 2$ mm
16.	Elbow iron 9 bars for frame size $40 \times 40 \times 2$ mm
17.	Pressure indicator

## 2.2. Experimental Apparatus

The parts planned in designing the machine are:

### 2.2.1. Tool Frame

A frame that functions to withstand the load of the components that afflict it, a frame that can withstand vibrations arising from the work process of the machine, a frame that has an alignment between the legs of the frame and supporting the engine components. The amount of loading in each field is as follows:

$$force = \frac{total\ mass \times\ grafitational\ force}{number\ of\ cross\ sections} \quad (1)$$

In order to use the L profile, the safety factor is taken from the Factor of Safety table [8] which for steel with continuous loads has FoS = 8. The tensile stress data of the allowable is taken from the ASTM Table which for iron A 36 has allowable stress ( $\sigma_i$ ) = 400 N / mm<sup>2</sup>.

Determination of the magnitude of the moment of inertia on the frame can be calculated by the formula:

Moment of inertia;

$$I = \frac{1}{12}bh^3 + Ah \quad (2)$$

Centre of gravity;

$$y = \frac{b^2}{2(I + b)} \quad (3)$$

Allowable tensile stress ( $\sigma_t$ );

$$\sigma_t = \frac{\sigma_i}{F} \quad (4)$$

Actual tensile stress

$$\sigma = \frac{M_{\max} \cdot y}{I} \quad (5)$$

where;

$M_{\max}$  = moment max

$y$  = center of gravity

$I$  = moment of inertia

$b$  = elbow width

$h$  = elbow height

The minimum thickness of the test tube wall is determined based on the following equation

$$t = \frac{PR}{SE \cdot 0.6P} \quad (6)$$

where;

$t$  = wall thickness (mm)

$P$  = maximum pressure based on design (bar)

$R$  = fingers of the inner circle (mm)

$S$  = maximum material stress / stress specification on material standard (bar)

$E$  = connection thickness efficiency

The minimum thickness of the test tube head uses the external pressure and internal pressure methods [9]. Determination of maximum internal pressure is obtained by the following formula;

$$t = d\sqrt{0.13P/SE} \quad (7)$$

where:

$t$  = minimum required head thickness (mm).

$d$  = inner diameter (mm)

$P$  = designed or outside pressure (bar).

$S$  = maximum pressure on the material (bar).

$E$  = thickness efficiency.

Whereas the determination of external pressure is obtained based on the following equation

$$P_a = \frac{P}{(R/t)} \quad (8)$$

where;

$P_a$  = maximum working pressure (bar)

$P$  = standard operating pressure specified (bar)

$R$  = outer tube radius (mm)

$t$  = minimum thickness required (mm)

### 2.2.2. Vacuum air flow velocity

By using the quantity equation, the flow velocity of the vacuum hose can be determined. Flow velocity in vacuum hose is [10]:

$$Q = V \cdot A \quad (9)$$

$$V = \frac{Q}{A} = \frac{Q}{\frac{\pi}{4}d^2}$$

Where:

$Q$  = volumetric flow capacity (m<sup>3</sup>/s)

$V$  = flow velocity (m/s)

$A$  = cross sectional area (m<sup>2</sup>)

### 2.3. Application control and test simulation method

For automatic applications, automatic applications on vacuum motors and pneumatic solenoid valves are used to regulate the pressure on the body using the application and software modification on the Arduino microcontroller by initializing and writing program listings.

The skeletal construction simulation is used to determine the overall strength of the frame which will later be the result of a comparison between experiments. The simulation uses an Autodesk Inventor computer simulation program licensed by the Student Version. Simulations are carried out to determine the shape and strength of the framework of a generic drug packaging machine so that the tool is able to withstand the pressure coming from pneumatics. This part of the frame is the place for all components in the assembly so that the shape, size and material are designed to support the performance of other components as a whole machine. For validation based on comparing the properties of the material used for the framework including:

- Hollow iron according to ASTM standard, the material is A 36
- Angle iron according to ASTM standard A36 material
- Iron plate according to JIS Material standard SPHE

## 3. Results and Discussion

### 3.1. Functional Design

The following is a three-dimensional design display for generic drug packaging leak testing machines:

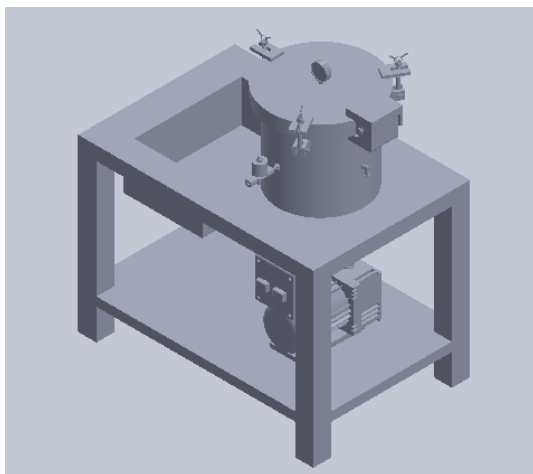

**Figure 1.** Machine design drawings



**Figure 2.** The shape of the machine after working on

### 3.2. Numerical Control Design (Arduino Uno)

Application and modification of software on the Arduino microcontroller is intended to make automatic motor vacuum and pneumatic solenoid valves. This will take the form of initializing and writing program listings.

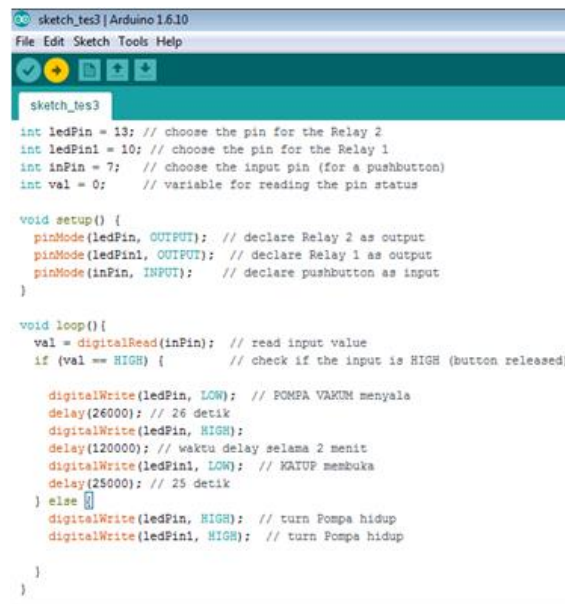

```

sketch_tes3 | Arduino 1.6.10
File Edit Sketch Tools Help

sketch_tes3

int ledPin = 13; // choose the pin for the Relay 2
int ledPin1 = 10; // choose the pin for the Relay 1
int inPin = 7; // choose the input pin (for a pushbutton)
int val = 0; // variable for reading the pin status

void setup() {
  pinMode(ledPin, OUTPUT); // declare Relay 2 as output
  pinMode(ledPin1, OUTPUT); // declare Relay 1 as output
  pinMode(inPin, INPUT); // declare pushbutton as input
}

void loop() {
  val = digitalRead(inPin); // read input value
  if (val == HIGH) { // check if the input is HIGH (button released)

    digitalWrite(ledPin, LOW); // POMPA VAKUM menyala
    delay(26000); // 26 detik
    digitalWrite(ledPin, HIGH);
    delay(120000); // waktu delay selama 2 menit
    digitalWrite(ledPin1, LOW); // KATUP membuka
    delay(25000); // 25 detik
  } else {
    digitalWrite(ledPin, HIGH); // turn Pompa hidup
    digitalWrite(ledPin1, HIGH); // turn Pompa hidup
  }
}

```

**Figure 3.** Numerical Control Design

### 3.3. Simulation of frame strength

The following is an analysis on the framework of a generic drug leak testing machine by accepting a total force of 493.5 N, with the material used A 36.

Stress shows the strength of the force that causes changes in the shape of objects. Stress is defined as the ratio between the forces acting on an object and the cross-sectional area of an object. The stress that occurs in the framework as follows:

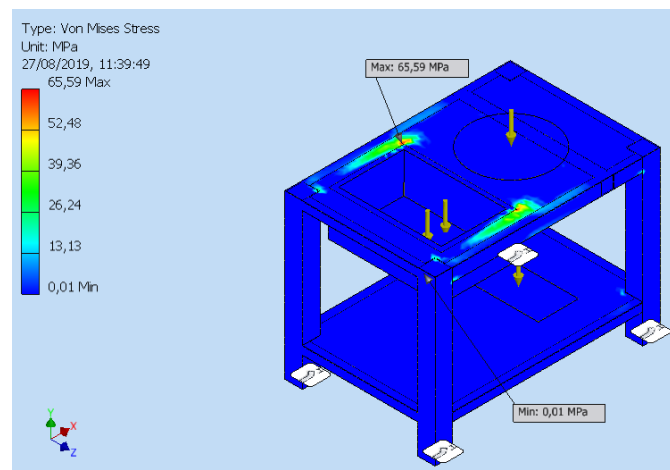
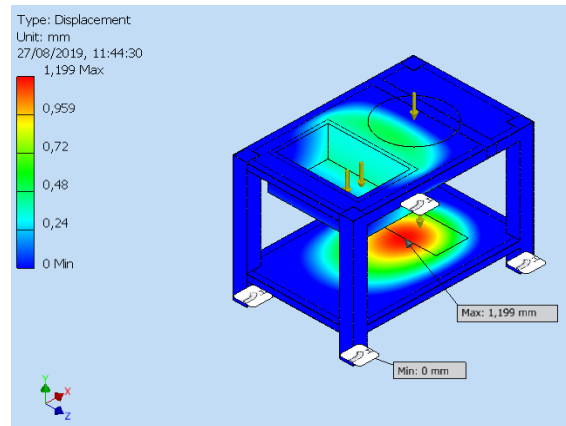

**Figure 4.** The stress simulation results on the frame

The picture above shows the stress that occurs in the framework of a generic drug packaging leak testing machine. The red color shows the greatest stress which is 65.59 MPa experienced in the frame, this is said to be safe for making the frame. Because the biggest load received on the frame is 65.59 MPa less than the material allowable stress which is 250 MPa. This stress occurs because of the emphasis made by loading the upper frame by 427.5 N and the bottom loading by 66 N. The maximum amount of stress that occurs in the upper loading.

### 3.4. Deflection

Deflection is a change in shape on objects in force. If the burden is greater the deflection produced will be even greater, whereas if the load is smaller the deflection generated will be smaller. Deflection that occurs in the framework as follows:



**Figure 5.** Deflection simulation results on the frame

The picture above shows that the engine frame has a load which results in transformation. The blue colour indicates deflection of 0 mm and red colour indicates the greatest deflection of 1.199 mm experienced by the frame. The result of the deflection shows that the structure still meets the safety requirements, because the largest stress load received on the frame is 1.199 mm smaller than the material allowable stress which is 15 mm (A 36)

### 3.5. Test Tube Wall Thickness Analysis

Determination of the minimum thickness of the test tube wall thickness is obtained based on the following equation

Where;

$$P = 1.5 \text{ bar}, R = 160 \text{ mm}, S = 270 \text{ MPa}, E = 1$$

Determination of the minimum wall thickness is obtained based on the following equation

$$t = \frac{PR}{SE \cdot 0.6P}$$

$$t = \frac{1,5 \times 160}{(2700 \times 1) \cdot (0.6 \times 1.5)} = 0.09 \text{ mm}$$

### 3.6. Test Tube Head Thickness Analysis

Determination of the minimum thickness of the test tube head is obtained based on the following equation.

For internal pressure

Where;

$$d = 320 \text{ mm}, P = 1.5 \text{ bar}, S = 270 \text{ MPa} = 2700 \text{ bar}, E = 1$$

$$t = d \sqrt{0.13 P / SE}$$

$$t = 320 \sqrt{\frac{0.13 \times 1.5}{2700 \times 1}} = 2.71 \text{ mm}$$

$$\text{Check limit: } t / d = (2.719) / 320 = 8.5 \times 10^{-3} \text{ mm}$$



Comparison of head thickness with inner diameter is still safe.

For external pressure

Where;

$P_a = 1$  bar,  $P = 0.4053$  bar,  $R = 163$  mm

$$P_a = \frac{P}{(R/t)}$$

$$-1 = \frac{0.4053}{(163/t)} t = \frac{-163}{0.4053} = 402.17 \text{ mm}$$

Boundary checking:  $t / d = 402.17 / 326 = 1.23$

Comparison of head thickness with inner diameter is still safe.

### 3.7. Vacuum Airflow Velocity Analysis

To calculate the flow velocity of a vacuum hose can be calculated:

Vacuum pump specifications  $Q = 56.633$  liter/min

$$V = \frac{Q}{A} = \frac{Q}{\frac{\pi}{4} d^2}$$

$$V = \frac{56.633}{\frac{\pi}{4} (0.01)^2}$$

$$V = \frac{5.633 \times 10^{-3} \text{ m}^3/\text{min}}{7.853 \times 10^{-5} \text{ m}^2} = 721.8 \text{ m/min}$$

Then the air flow velocity in the vacuum hose is 721.08 m/min

### 3.8. Discussion

Coding program that has been completed is then uploaded so that the Arduino micron can read the program so that it can run according to what has been coding. Then the results can work automatically using the Arduino UNO program. from the vacuum process, the waiting time is 2 minutes, marking the completion of the testing of the outlet valve (solenoid valve), until the pressure indicator scale returns to zero and the alarm sounds

From the calculation results of this stress simulation occurs because the emphasis made by loading the upper frame is 427.5 N and the bottom loading is 66 N. The deflection results show the structure still meets safety requirements, because the largest stress load received on the frame is 1.199 mm smaller than the material permit voltage which is 15 mm (A 36). Things that must be considered in the process of making a drug packaging leak testing machine framework is to determine the strength of the frame in order to carry all the engine components. Based on theoretical calculations, the strength of the frame is 105 992.268 N/m<sup>2</sup>

## 4. Conclusions

The conclusions from the results of this study are as follows, the specification of the design and testing machine of the automatic generic drug packaging leak testing machine with a compressive capacity of 0.4 atm has dimensions: 900 mm x 600 mm x 906 mm. The vacuum device uses a HP vacuum pump used for the leak testing machine for drug packaging with a suction capacity of 2 cfm. The process of making a drug packaging leak testing machine framework that is determining the strength of the frame

in order to mount all the components of the machine. Based on theoretical calculations, the strength of the frame is 105 992.268 N/m<sup>2</sup>. The controller system works automatically using the Arduino UNO program, a vacuum process with a waiting time of 2 minutes, a sign of the completion of the solenoid valve testing opening, until the pressure indicator scale returns to zero and the alarm sounds.

### References

- [1] Knoll D, Neumeier D, Prüglmeier M, and Reinhart G 2019 An automated packaging planning approach using machine learning *52nd CIRP Conference on Manufacturing Systems, Procedia CIRP* **81** 576–581.
- [2] Kossinna J, and Meyer A 2010 Helium leak testing of packages for oral drug products. *European J. Pharm. and Bio.* **75(2)** 297–303.
- [3] ASTM F2338-09 2013 *Standard Test Method for Nondestructive Detection of Leaks in Packages* by Vacuum Decay Method.
- [4] Dawidowicz A. L., et.all 2019 Effect of food packaging material on some physicochemical properties of polyacrylate varnish layers *J. Food. Pck. and Shlf Lfe*, 21.
- [5] Gerhart J M, Spriggs H, Hampton T W, Hoy R M B, Strohlic A Y, Proulx S, and Goetchius D. B 2015. Applying human factors to develop an improved package design for (Rx) medication drug labels in a pharmacy setting *J. Safty Rsrch.* **55** 177–184.
- [6] DIN55405 *Packaging - Terminology - Terms and definitions* Amendment A1 2014
- [7] Herman Adi Prasetya and Sutono 2019 Design of leak test equipment on microcontroller-based mineral water bottles *J. JBBT Unikom Bandung*.
- [8] Khurmi R S and Gupta J K 2005 *Machine Design*. Ram Nagar New Delhi Eurasia Publishing House (PVT).
- [9] Megyesy E F 1997 *Pressure vessel handbook 10th edition*. Tulsa Pres.Vssl. Publishing Inc.
- [10] Ryans J L, dan Roper D L 1986 *Process Vacuum System Design & Operation* McGraw-Hill.