

LAMPIRAN

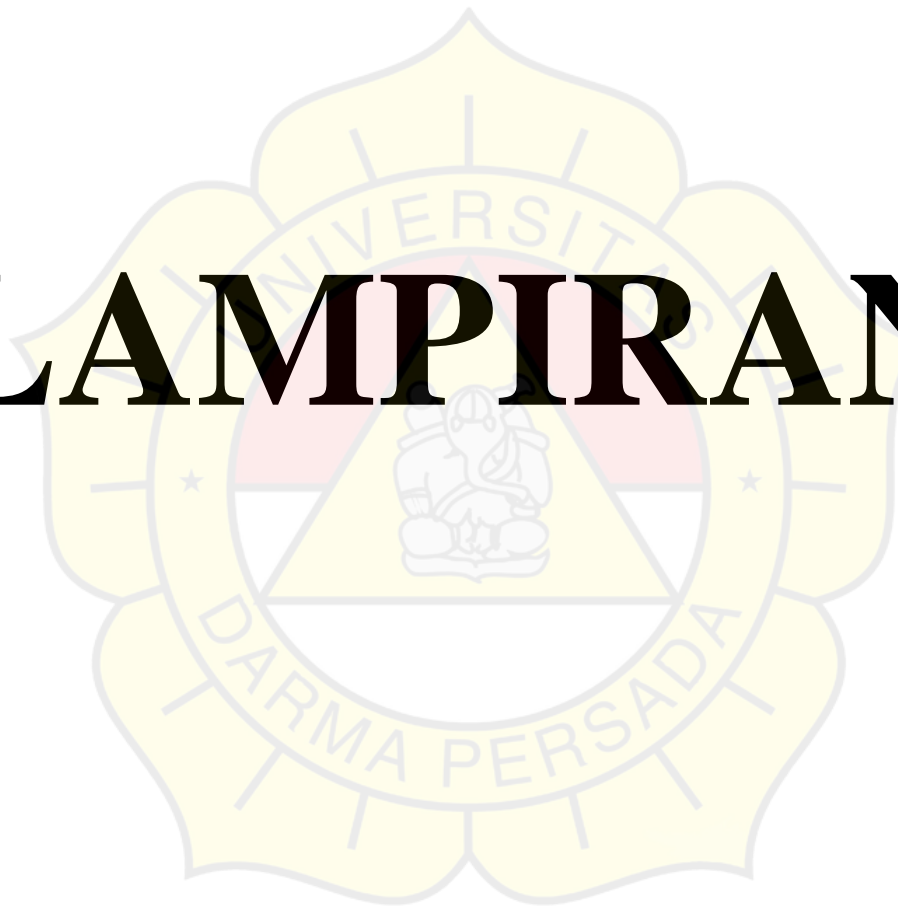

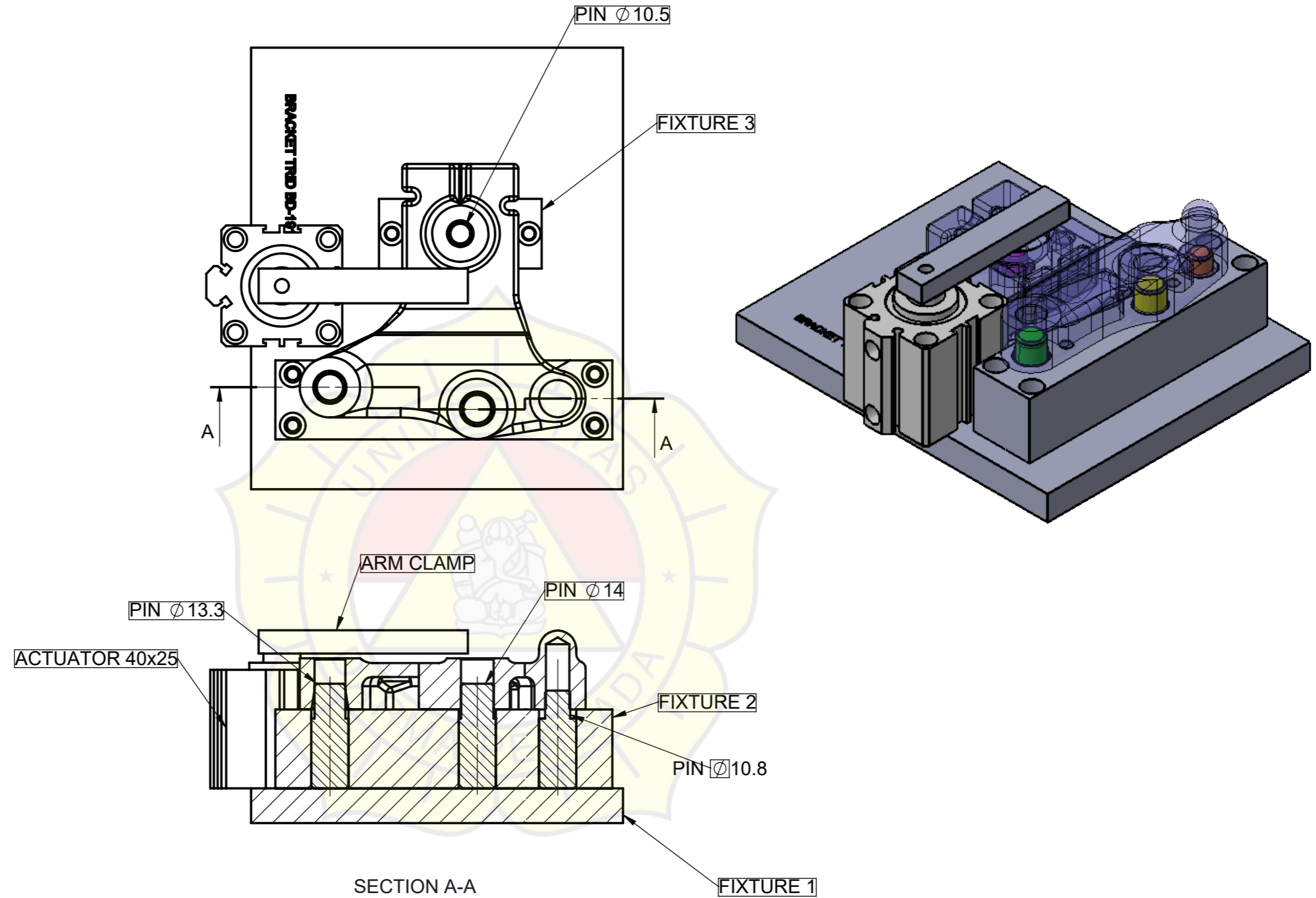

NOTE :
 1.QTY : 1 PC.
 2.No sharp edge, C1

GENERAL TOLERANCE(MEDIUM)	NO	REVISION	DATE	SIGNED
over 0.5 up to 6	±0.1			
over 6 up to 30	±0.2			
over 30 up to 120	±0.3			
over 120 up to 315	±0.5			
over 315 up to 1000	±0.8			
over 1000 up to 2000	±1.2			

MATERIAL	WEIGHT	PROJECTION	APPVD	CKHD	DSGND	DRWN	DATE
---			Husen A.	Husen A.	Risky P.	Risky P.	27-06-2023
CUSTOMER :			NAME :				
HEAT TREATMENT		HARDNESS	SCALE		SIMULASI JIG MILLING OP2		
		SURF :	1 : 2				
CASE DEPTH :		CORE :	BRACKET BD-191				
A3	UNIVERSITAS DARMA PERSADA		PART NO.		DRW NO.		

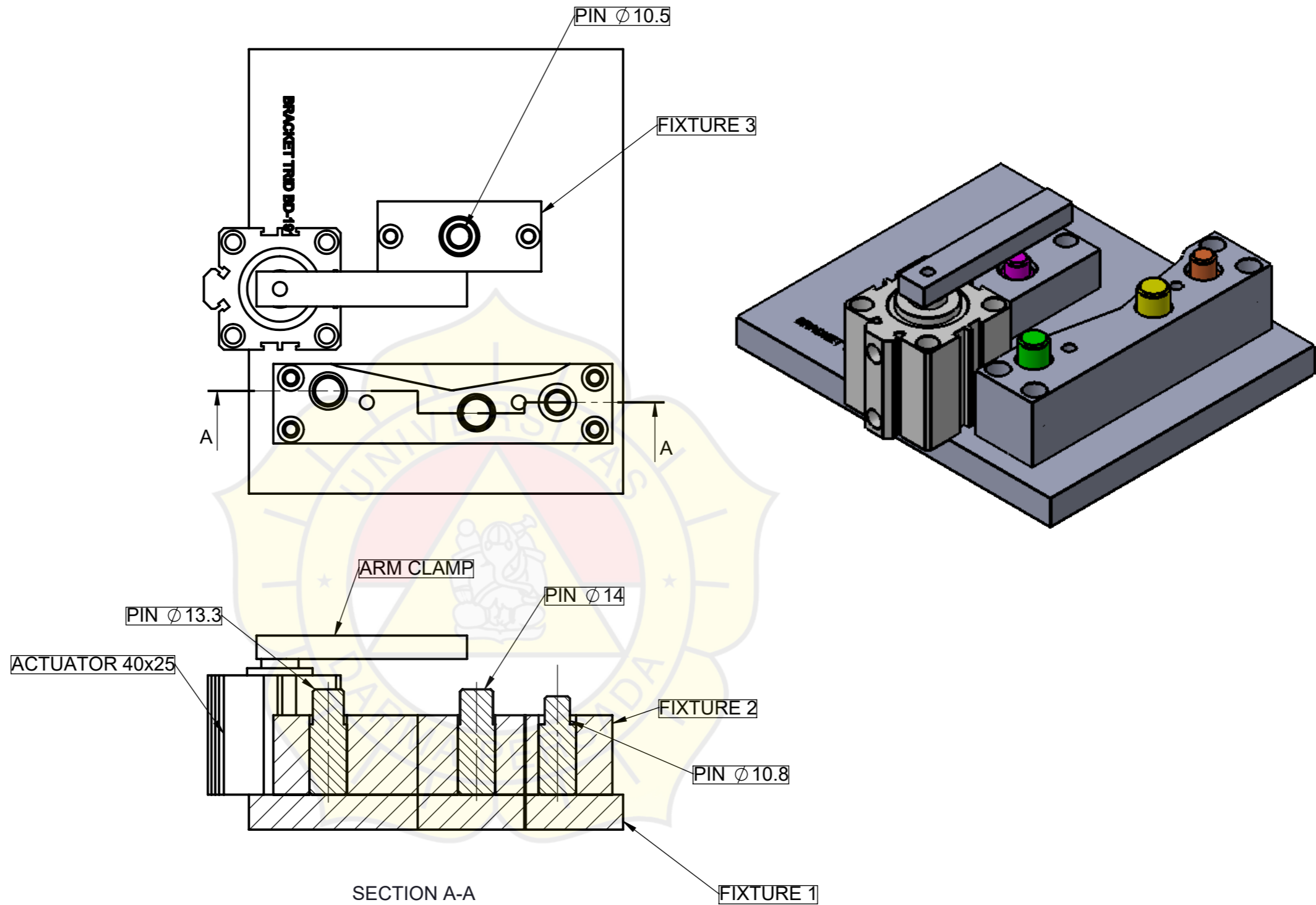

NOTE :
 1.QTY : 1 PC.
 2.No sharp edge, C1

GENERAL TOLERANCE(MEDIUM)	NO	REVISION	DATE	SIGNED
over 0.5 up to 6	±0.1			
over 6 up to 30	±0.2			
over 30 up to 120	±0.3			
over 120 up to 315	±0.5			
over 315 up to 1000	±0.8			
over 1000 up to 2000	±1.2			

MATERIAL	WEIGHT	PROJECTION	APPVD	CKHD	DSGND	DRWN	DATE
---			Husen A.	Husen A.	Risky P.	Risky P.	27-06-2023
CUSTOMER :			NAME :				
HEAT TREATMENT		HARDNESS	SCALE		SIMULASI JIG MILLING OP2		
		SURF :	1 : 2				
CASE DEPTH :		CORE :					
A3	UNIVERSITAS DARMA PERSADA		BRACKET BD-191		PART NO.		DRW NO.

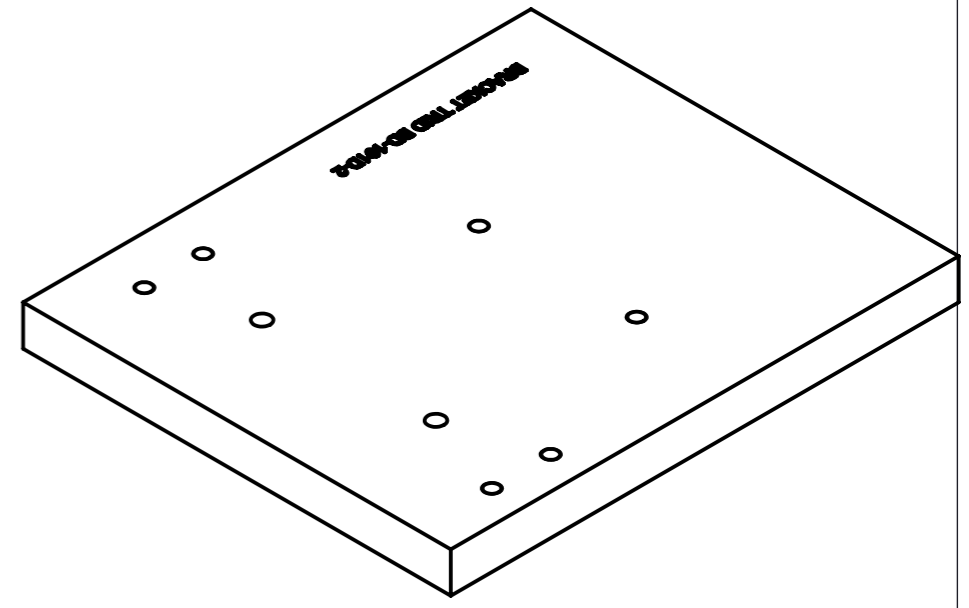
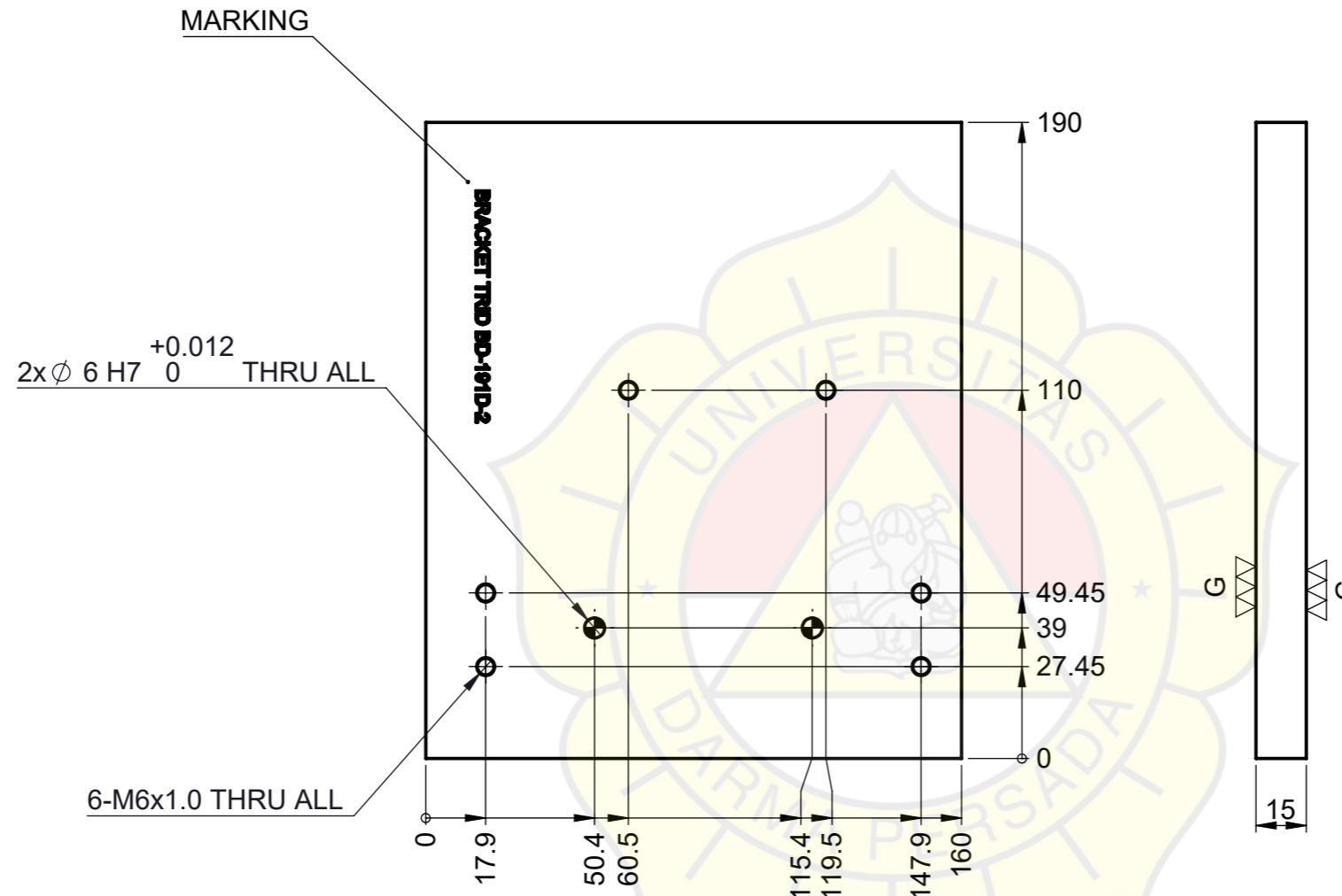

NOTE :
 1.QTY : 1 PC.
 2.No sharp edge, C1

GENERAL TOLERANCE(MEDIUM)	NO	REVISION	DATE	SIGNED
over 0.5 up to 6	±0.1			
over 6 up to 30	±0.2			
over 30 up to 120	±0.3			
over 120 up to 315	±0.5			
over 315 up to 1000	±0.8			
over 1000 up to 2000	±1.2			

MATERIAL SS 41	WEIGHT	PROJECTION 	APPVD Husen A.	CKHD Husen A.	DSGND Risky P.	DRWN Risky P.	DATE 27-06-2023
CUSTOMER :			NAME :				
HEAT TREATMENT		HARDNESS	SCALE 1 : 2		FIXTURE 1 JIG MILLING OP 2		
CASE DEPTH :		CORE :					
A3	UNIVERSITAS DARMA PERSADA		PART NO.		DRW NO.		

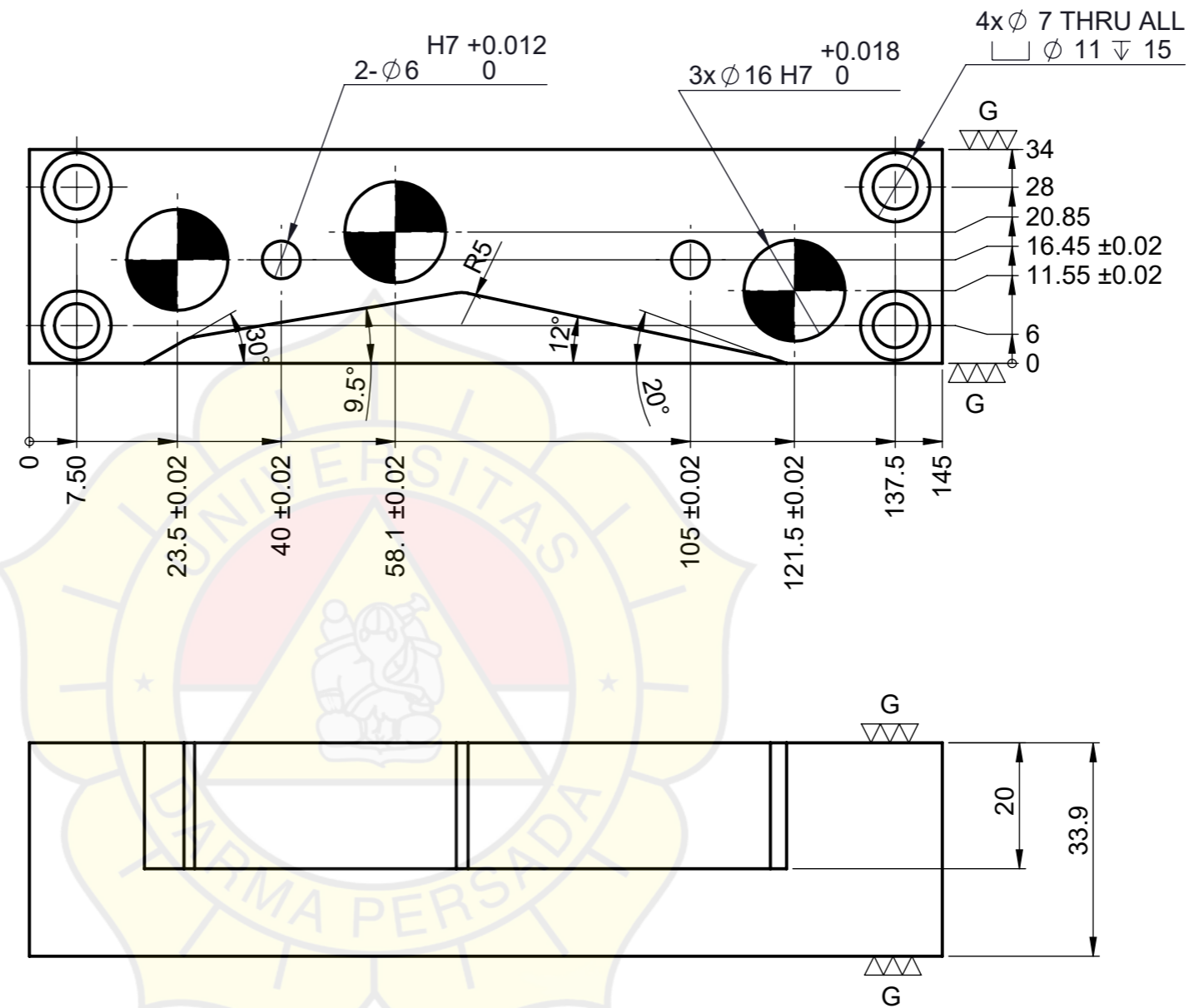
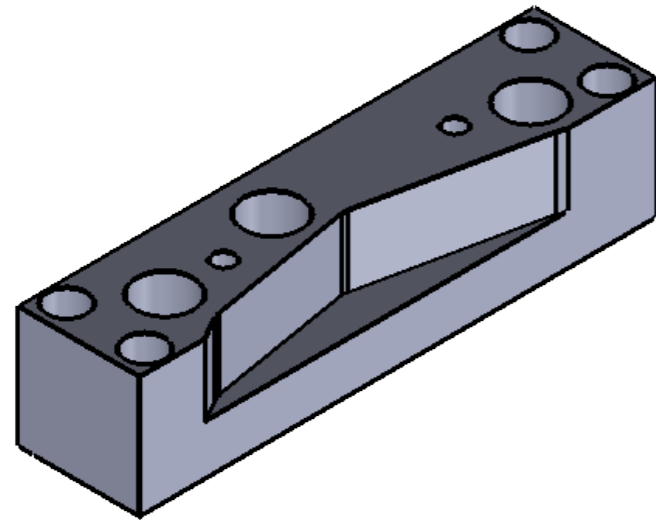

NOTE :
 1.QTY : 1 PC.
 2.No sharp edge, C1

GENERAL TOLERANCE(MEDIUM)	NO	REVISION	DATE	SIGNED
over 0.5 up to 6	± 0.1			
over 6 up to 30	± 0.2			
over 30 up to 120	± 0.3			
over 120 up to 315	± 0.5			
over 315 up to 1000	± 0.8			
over 1000 up to 2000	± 1.2			

MATERIAL	WEIGHT	PROJECTION	APPVD	CKHD	DSGND	DRWN	DATE
SS 41			Husen A.	Husen A.	Risky P.	Risky P.	27-06-2023
CUSTOMER :			NAME :				
HEAT TREATMENT		HARDNESS	SCALE		FIXTURE 2 JIG MILLING OP2		
		SURF :	1 : 2				
CASE DEPTH :		CORE :					
A3	UNIVERSITAS DARMA PERSADA		BRACKET BD-191		PART NO.		DRW NO.

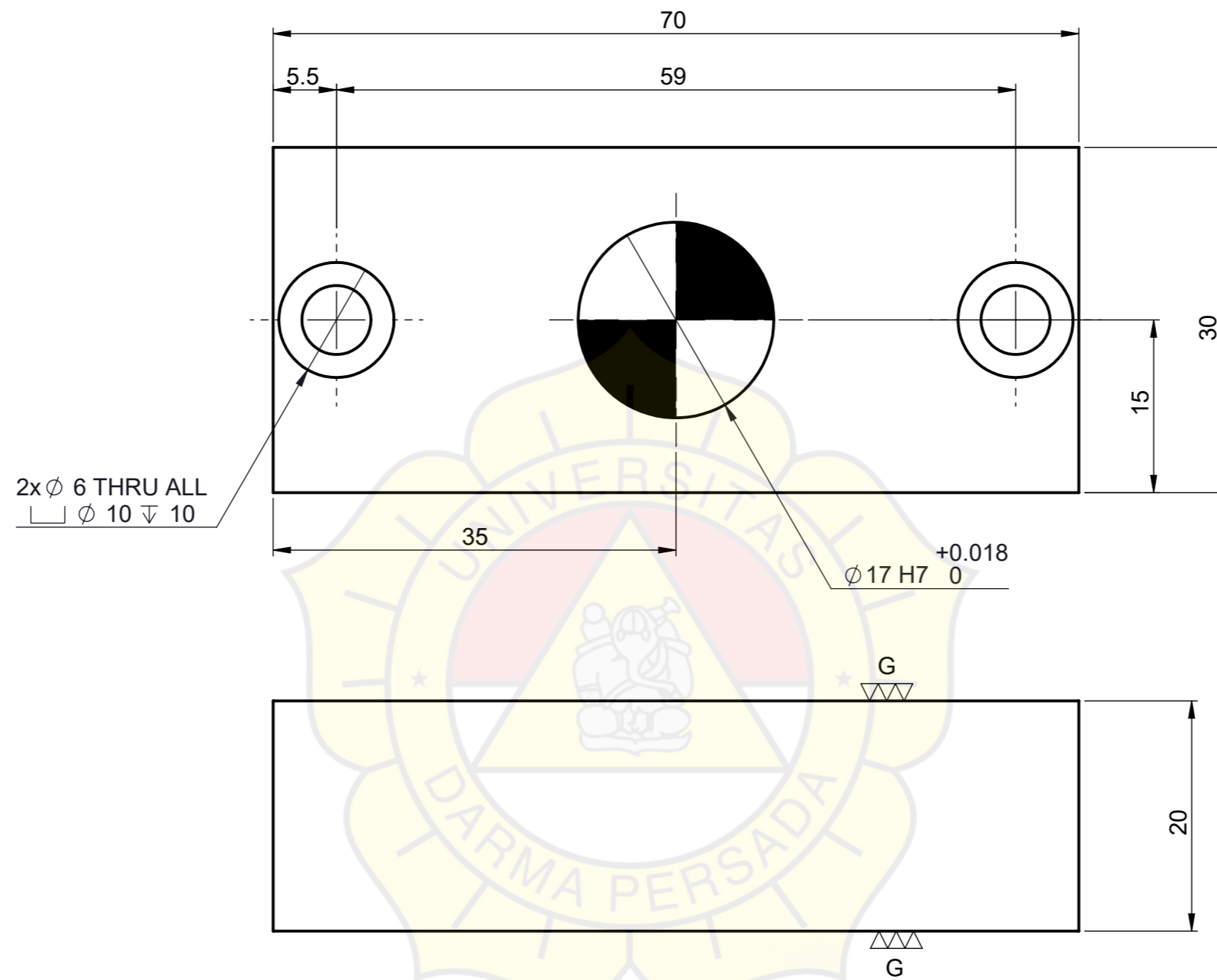

NOTE :
1.QTY : 1 PC.
2.No sharp edge, C1

GENERAL TOLERANCE(MEDIUM)	NO	REVISION	DATE	SIGNED
over 0.5 up to 6	± 0.1			
over 6 up to 30	± 0.2			
over 30 up to 120	± 0.3			
over 120 up to 315	± 0.5			
over 315 up to 1000	± 0.8			
over 1000 up to 2000	± 1.2			

MATERIAL	WEIGHT	PROJECTION	APPVD	CKHD	DSGND	DRWN	DATE
SS 41			Husen A.	Husen A.	Risky P.	Risky P.	27-06-2023
CUSTOMER :			NAME :				
HEAT TREATMENT		HARDNESS	SCALE		FIXTURE 3 JIG MILLING OP2		
		SURF :	1 : 2				
CASE DEPTH :		CORE :		BRACKET BD-191			
A3	UNIVERSITAS DARMA PERSADA		PART NO.		DRW NO.		

GENERAL TOLERANCE(MEDIUM)	NO	REVISION	DATE	SIGNED
over 0.5 up to 6	±0.1			
over 6 up to 30	±0.2			
over 30 up to 120	±0.3			
over 120 up to 315	±0.5			
over 315 up to 1000	±0.8			
over 1000 up to 2000	±1.2			

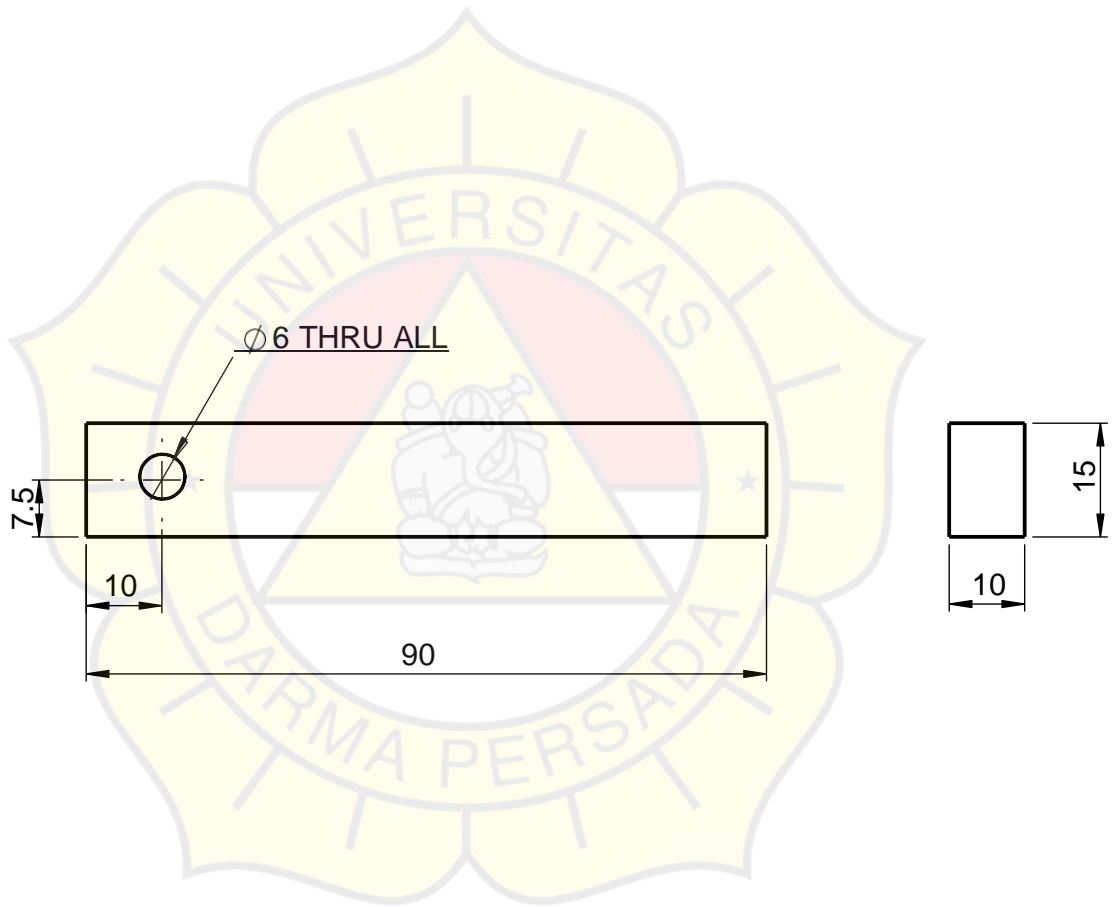

MATERIAL SCM 415	WEIGHT	PROJECTION 	APPVD Husen A.	CKHD Husen A.	DSGND Risky P.	DRWN Risky P.	DATE 27-06-2023
CUSTOMER :			NAME :				
HEAT TREATMENT C-Q-T	HARDNESS SURF : 58-62 HRC	SCALE 1:1	ARM CLAMP JIG MILLING OP 2				
CASE DEPTH :	CORE :						
A4	UNIVERSITAS DARMA PERSADA		PART NO.		DRW NO.		

GENERAL TOLERANCE(MEDIUM)	NO	REVISION	DATE	SIGNED
over 0.5 up to 6	±0.1			
over 6 up to 30	±0.2			
over 30 up to 120	±0.3			
over 120 up to 315	±0.5			
over 315 up to 1000	±0.8			
over 1000 up to 2000	±1.2			

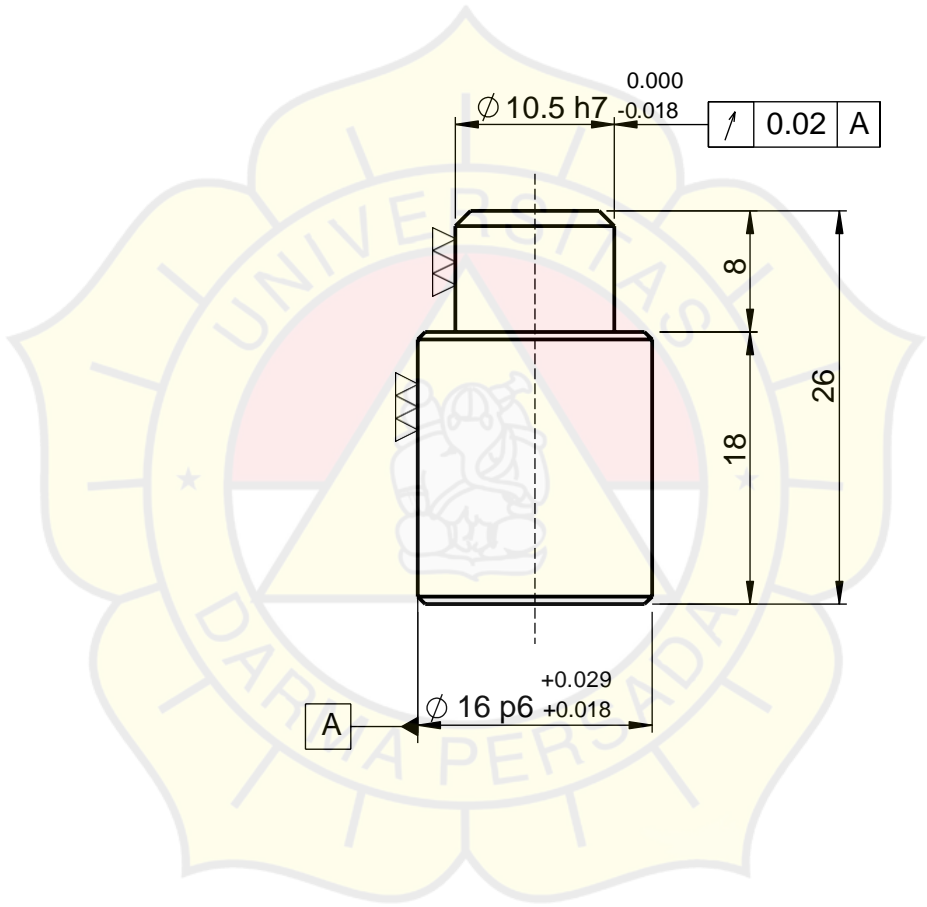

- NOTE :
- SUDUT TAJAM C0.5.
 - QTY 1PC.

MATERIAL SCM 415	WEIGHT	PROJECTION 	APPVD Husen A.	CKHD Husen A.	DSGND Risky P.	DRWN Risky P.	DATE 27-06-2023
CUSTOMER :			NAME :				
HEAT TREATMENT C-Q-T		HARDNESS SURF : 58-60HRC	SCALE 2:1		PIN LOCK ϕ 10.5 JIG MILLING OP2		
CASE DEPTH :		CORE :		BRACKET BD-191			
A4	UNIVERSITAS DARMA PERSADA		PART NO.			DRW NO.	

GENERAL TOLERANCE(MEDIUM)				NO	REVISION	DATE	SIGNED
over 0.5	up to	6	±0.1				
over 6	up to	30	±0.2				
over 30	up to	120	±0.3				
over 120	up to	315	±0.5				
over 315	up to	1000	±0.8				
over 1000	up to	2000	±1.2				

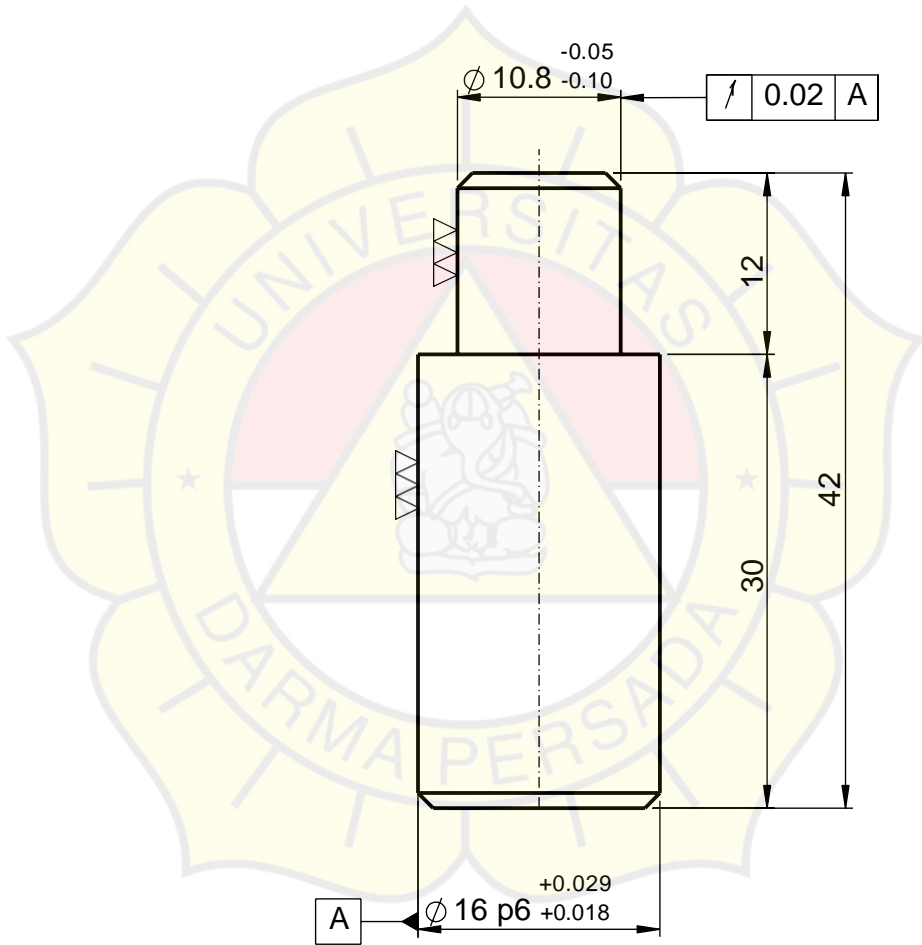

MATERIAL SCM 415	WEIGHT	PROJECTION 	APPVD Husen A.	CKHD Husen A.	DSGND Risky P.	DRWN Risky P.	DATE 27-06-2023
CUSTOMER :			NAME :				
HEAT TREATMENT C-Q-T		HARDNESS SURF : 58-62 HRC	SCALE 2:1		PIN LOCK ϕ 10.8 JIG MILLING OP 2		
CASE DEPTH :	CORE :		BRACKET BD-191				
A4	UNIVERSITAS DARMA PERSADA		PART NO.		DRW NO.		

GENERAL TOLERANCE(MEDIUM)	NO	REVISION	DATE	SIGNED
over 0.5 up to 6	±0.1			
over 6 up to 30	±0.2			
over 30 up to 120	±0.3			
over 120 up to 315	±0.5			
over 315 up to 1000	±0.8			
over 1000 up to 2000	±1.2			

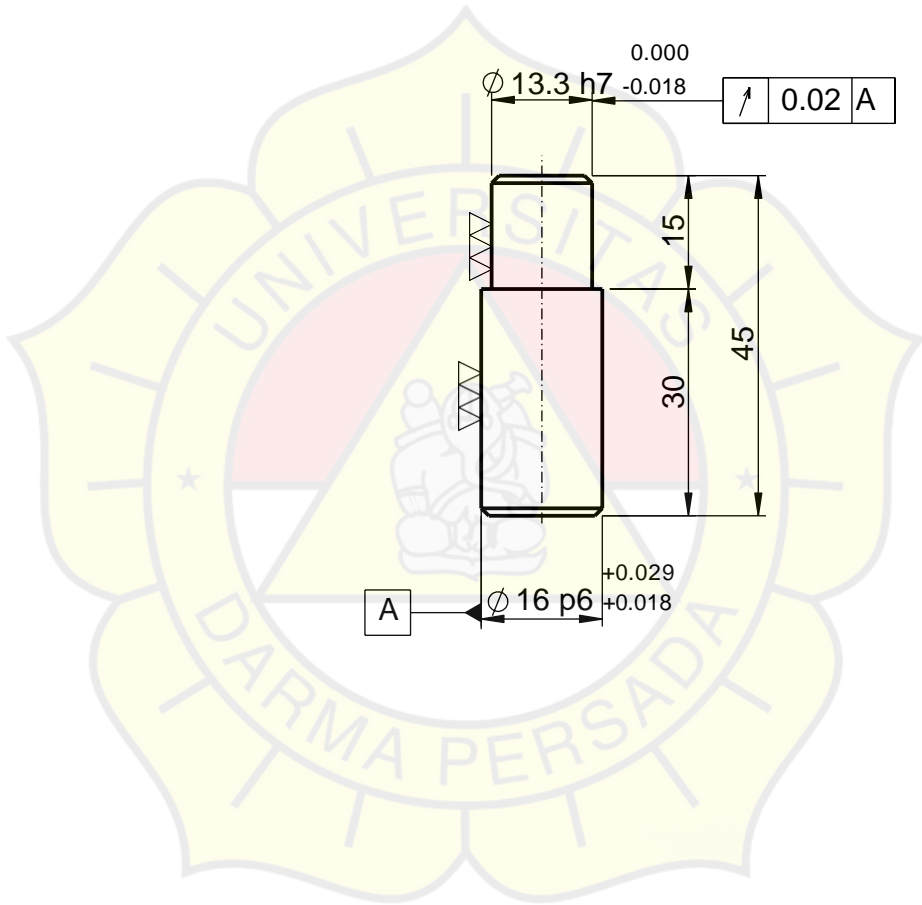

NOTE :

1. SUDUT TAJAM C0.5.
2. QTY 1Pc.

MATERIAL SCM 415	WEIGHT	PROJECTION 	APPVD Husen A.	CKHD Husen A.	DSGND Risky P.	DRWN Risky P.	DATE 27-06-2023
CUSTOMER :			NAME :				
HEAT TREATMENT C-Q-T		HARDNESS SURF : 58-62 HRC	SCALE 1:1		PIN LOCK 13.3 JIG MILLING OP2		
CASE DEPTH :	CORE :						
A4	UNIVERSITAS DARMA PERSADA		BRACKET BD-191 PART NO.		DRW NO.		

GENERAL TOLERANCE(MEDIUM)	NO	REVISION	DATE	SIGNED
over 0.5 up to 6	±0.1			
over 6 up to 30	±0.2			
over 30 up to 120	±0.3			
over 120 up to 315	±0.5			
over 315 up to 1000	±0.8			
over 1000 up to 2000	±1.2			

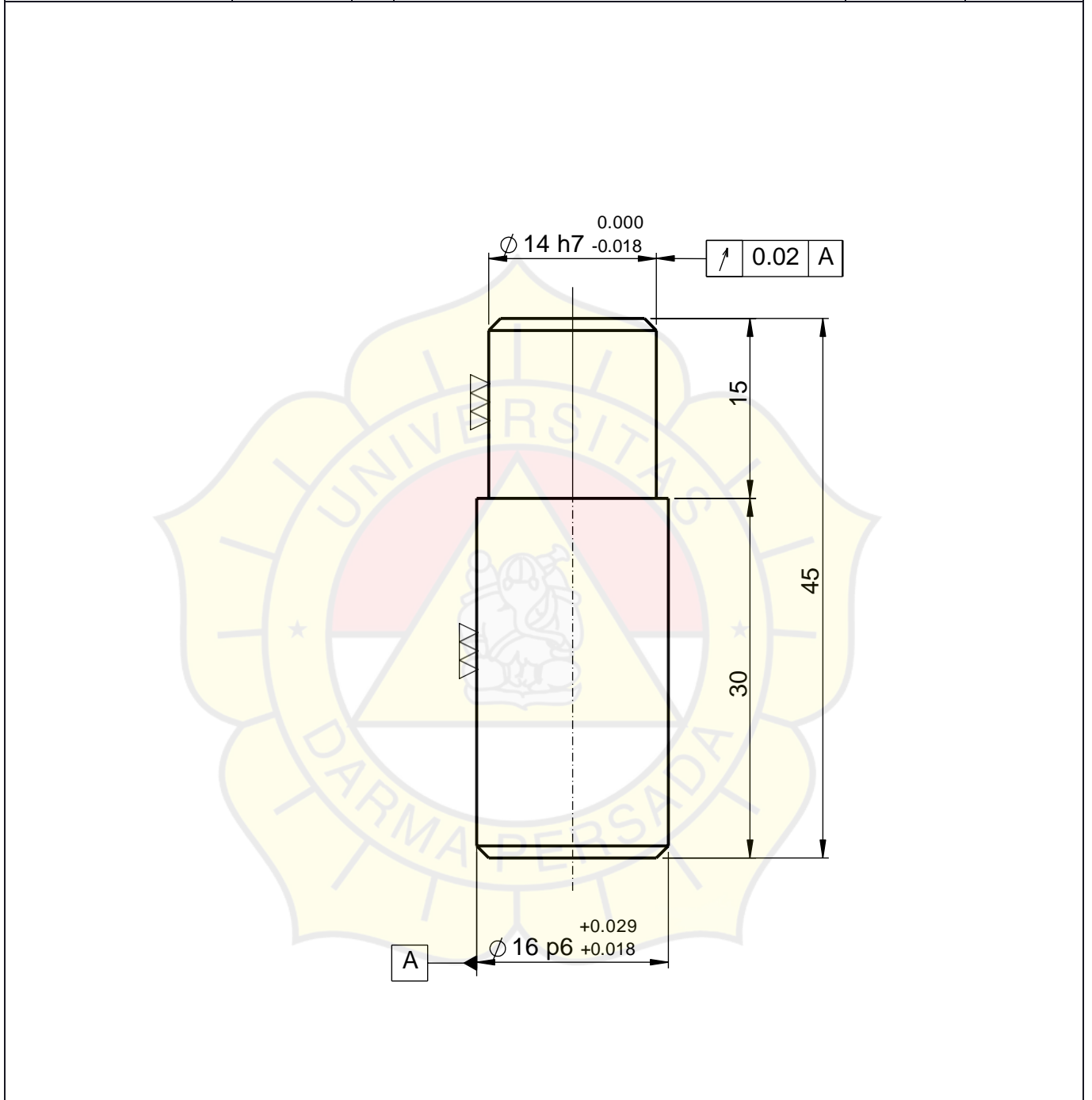

MATERIAL SCM 415	WEIGHT	PROJECTION 	APPVD Husen A.	CKHD Husen A.	DSGND Risky P.	DRWN Risky P.	DATE 27-06-2023
CUSTOMER :			NAME :				
HEAT TREATMENT C-Q-T		HARDNESS SURF : 58-62 HRC	SCALE 1:1		PIN LOCK ϕ 14 JIG MILLING OP 2		
CASE DEPTH :	CORE :						
A4	UNIVERSITAS DARMA PERSADA		PART NO.		DRW NO.		